



IALA RECOMMENDATION (INFORMATIVE)

R0205 (E-200-5) MARINE SIGNAL LIGHTS - PART 5 - ESTIMATION OF THE PERFORMANCE OF OPTICAL APPARATUS

Edition 1.1

December 2008

urn:mrn:iala:pub:r0205:ed1.1



DOCUMENT REVISION

Revisions to this document are to be noted in the table prior to the issue of a revised document.

Date	Details	Approval
December 2008	1 st issue	
September 2020	Edition 1.1 Editorial corrections.	



THE COUNCIL

RECALLING the function of IALA with respect to Safety of Navigation, the efficiency of maritime transport and the protection of the environment;

RECOGNIZING the need to provide guidance for the evaluation of performance of marine Aid-to-Navigation signal lights;

RECOGNIZING ALSO that it is not always possible to evaluate performance of marine Aid-to-Navigation signal lights by direct measurement;

RECOGNIZING FURTHER that it is possible to estimate the performance of marine Aid-to-Navigation signal lights by calculation;

NOTING that defined standards for the determination of the performance of flashing lights should be used worldwide to ensure the quality of signal lights for mariners;

NOTING ALSO that this document only applies to marine Aid-to-Navigation signal lights that are installed after the publication date of this document;

CONSIDERING the proposals of the EEP Committee, their lights experts and the IALABATT/IALALITE working group;

ADOPTS the Recommendation on Marine Aid-to-Navigation Signal Lights in the annexes of this recommendation; and,

RECOMMENDS that National Members and other appropriate Authorities providing marine aids to navigation adopt the methods in accordance with this recommendation for the estimation of the performance of optical apparatus.



ANNEX CONTENTS

ANNEX A	MARINE SIGNAL LIGHTS - ESTIMATION OF THE PERFORMANCE OF OPTICAL APPARATUS	7
1	INTRODUCTION	7
2	SCOPE / PURPOSE	7
3	DEFINITIONS	7
SECTION A - METHODS OF APPROXIMATE CALCULATION OF THE PEAK LUMINOUS INTENSITY OF THE BEAM FROM AN AID-TO-NAVIGATION LIGHT		8
1	PURPOSE.....	8
2	TYPES OF BEAM PROJECTION APPARATUS	8
3	TYPES OF LIGHT SOURCE	8
4	LUMINANCE OF LIGHT SOURCES.....	9
5	FORMULAE FOR CALCULATION OF PEAK BEAM INTENSITY	10
5.1	Projection Apparatus for a Fan Beam (generated around a vertical axis).....	10
5.1.1	Catoptric	10
5.1.2	Dioptric and Catadioptric.....	11
5.2	Projection Apparatus for a Pencil Beam	13
5.2.1	Catoptric	13
5.2.2	Dioptric and Catadioptric.....	14
5.2.3	Auxiliary Beams	15
5.3	Reinforcing Mirrors.....	15
5.3.1	Centred Reinforcing Mirrors	15
5.3.2	De-centred Reinforcing Mirrors	16
6	LIGHT DURATION OF RHYTHMIC BEAMS	16
6.1	Rotating Apparatus.....	16
6.2	Blanking Systems	17
6.3	Extinction Systems.....	17
6.3.1	Acetylene and other Gas Flames, and Discharge Lamps.....	17
6.3.2	Incandescent Lamps and Mantle Burners	17
7	USE OF COLOUR FILTERS.....	18
8	METHODS OF DEDUCING ATMOSPHERIC TRANSMISSION FROM LIGHTHOUSE OBSERVATION.....	19
9	EFFECT OF LANTERN GLAZING AND SERVICE CONDITIONS FACTOR	21
10	LIMITATIONS OF THE CALCULATIONS	21
SECTION B - ESTIMATION OF BEAM INTENSITY BY RATIO-ING TECHNIQUES		27
1	PURPOSE.....	27



ANNEX CONTENTS

2	EXAMPLES OF ESTIMATION OF LUMINOUS INTENSITY	27
2.1	Fixed Lenses.....	27
2.1.1	Change of Source.....	27
2.1.2	Change of Fixed Lens Size	27
2.2	Optical Panels	28
2.2.1	Change of Source.....	28
2.2.2	Change of Optical Panel Size.....	29
3	EXAMPLES OF ESTIMATION OF BEAM DIVERGENCE.....	30
3.1	Scaling of Flash Duration	30
4	CONCLUSIONS.....	31
5	REFERENCES.....	31

List of Tables

<i>Table 1</i>	<i>Reinforcing Mirrors Correction Factors</i>	<i>16</i>
<i>Table 2</i>	<i>Average Transmission Factors of Coloured Filters.....</i>	<i>18</i>
<i>Table 3</i>	<i>Percentage Frequency of Observing Neighbouring Lighthouses</i>	<i>20</i>

List of Figures

<i>Figure 1</i>	<i>Correction Factor k_1.....</i>	<i>11</i>
<i>Figure 2</i>	<i>Correction Factors k_2.....</i>	<i>12</i>
<i>Figure 3</i>	<i>Correction Factors k_3 and k_4.....</i>	<i>13</i>
<i>Figure 4</i>	<i>Correction Factor c_2.....</i>	<i>14</i>
<i>Figure 5</i>	<i>Correction Graph for Incandescence and Nigrescence Time</i>	<i>18</i>
<i>Figure 6</i>	<i>Distribution Curve of Atmospheric Transmission.....</i>	<i>21</i>
<i>Figure 7</i>	<i>Example 1 – Drawing of 2nd Order Rotating Optic.....</i>	<i>22</i>
<i>Figure 8</i>	<i>Drawing of a 4th Order Optic</i>	<i>25</i>

List of Equations

<i>Equation 1</i>	<i>Mean luminance of a source in any given direction</i>	<i>9</i>
<i>Equation 2</i>	<i>Luminous intensity (I_0) at the peak of the beam from a catoptric fan beam projection apparatus.....</i>	<i>10</i>



ANNEX CONTENTS

Equation 3	Luminous intensity (I_0) at the peak of the beam from a dioptric and catadioptric fan beam projection apparatus.....	11
Equation 4	Luminous intensity (I_0) at the peak of the beam from a catoptric pencil beam projection apparatus.....	13
Equation 5	Luminous intensity (I_0) at the peak of the beam from a dioptric and catadioptric pencil beam projection apparatus.....	14
Equation 6	Luminous intensity (I_0) at the peak of the beam from a dioptric and catadioptric pencil beam projection apparatus with filament lamp source	15
Equation 7	Increased intensity of a fan beam from de-centered reinforcing mirrors	16
Equation 8	Angle of light beam in projection apparatus.....	16
Equation 9	Duration of an appearance of light	17
Equation 10	Intensity of a light from atmospheric transmission.....	20
Equation 11	Atmospheric transmission from observations from neighbouring lighthouses	20
Equation 12	Luminance intensity of light source.....	22
Equation 13	Intensity of similar lens with same light source using comparison method.....	28
Equation 14	Intensity scaled from luminance of the light source	28
Equation 15	Flash duration using comparison method	30

ANNEX A MARINE SIGNAL LIGHTS - ESTIMATION OF THE PERFORMANCE OF OPTICAL APPARATUS

1 INTRODUCTION

This recommendation is divided into two Sections A and B.

The recommended way of determining the performance of optical apparatus is by direct measurement, see reference [5]. However, when direct measurement is not possible the performance may be estimated as follows:

Section A gives details of a method for the approximate calculation of the peak luminous intensity of a beam from an aid-to-navigation light, i.e. the intensity at a maximum of its distribution in space, usually in the direction of the optical axis of the beam projection system.

This type of calculation is intended for use when direct photometric measurement is not possible and when the data required for the methods of Section B are not available.

Section B describes methods by which it is possible to obtain better estimates of luminous intensity for a given source-optic combination, than those obtainable by the methods of Section A, provided that measured data are available for an identical optic with other sources or for an identical source with other optics.

This type of calculation is preferred to that of Section A, where possible.

2 SCOPE / PURPOSE

The purpose of this recommendation is to describe how to determine or to estimate one or more figures of luminous intensity to provide meaningful descriptors of the performance of a marine aid-to-navigation signal light when it is used at an installation. It will rarely be possible to make the necessary measurements on the installed light in situ, but for the majority of lights it should be possible to measure the spatial distribution of luminous intensity of the beam or beams of light emitted, e.g. by a fixed lens or by a number of prismatic lens panels, either on the actual equipment to be installed or on an exactly similar one. The measurements will usually be made at a photometric test site set up for this purpose. As far as possible, the equipment measured at the site should be identical in all particulars with that of the installation, including both colour filters and lantern glazing where applicable. In cases where these cannot be included in the measuring set-up, corrections for colour filter transmission factors may be derived from separate measurements and allowance for losses in lantern glazing may be made.

3 DEFINITIONS

Definitions are referenced to the IALA Dictionary.

SECTION A - METHODS OF APPROXIMATE CALCULATION OF THE PEAK LUMINOUS INTENSITY OF THE BEAM FROM AN AID-TO-NAVIGATION LIGHT

1 PURPOSE

As stated in the Introduction, the formulae given in this Section are intended only for use as a means of approximate estimation of the luminous intensity in the axial direction when it is not possible to make photometric measurements. The accuracy is likely to be no better than $\pm 20\%$ for sources approximating to spheres of uniform luminance and will usually be significantly lower for filament and compact source arc discharge lamps.

The formulae may also be used in the design stage of a new lighted aid, when they may be very useful as a guide to the size of panel, luminance of source, etc, required to meet a given operational need.

2 TYPES OF BEAM PROJECTION APPARATUS

The formulae of this Section apply to the following types of beam projection apparatus.

- 1 Catoptric systems, including paraboloidal and parabolic cylindrical reflectors;
- 2 Prismatic lens systems (with dioptric and/or catadioptric elements);
- 3 Auxiliary Systems:
 - a Diverting prisms;
 - b Reinforcing mirrors, e.g. spherical reflectors of either catoptric or catadioptric type.

The calculations have been made for systems having a Fresnel profile. It can be shown that the results are not very dependent on the shapes of the prisms, and the calculations may be applied with reasonable accuracy to other profiles, e.g. equi-angular. When the Fresnel profile includes catadioptric elements, these may be arranged to recede at high angles, or to remain in one plane. In the latter case, dark spaces occur between the prisms. Two separate sets of formulae are given, applicable respectively to optical panels and to drum lenses.

3 TYPES OF LIGHT SOURCE

The formulae apply strictly to sources having the form of spheres of uniform luminance. They are therefore capable of giving reasonably accurate results for sources which approximate to this form, such as mantle burners with large single incandescent mantles.

Additional correction factors are tabulated to permit approximate calculations for the following common types of incandescent electric lamp filaments:

- 1 Grid;
- 2 Cylindrical;
- 3 Cruciform;
- 4 Compact coiled-coil.

The application of the formulae to other forms of filament and other light sources such as open-flame burners, carbon arc lamps and high-pressure arc discharge lamps is subject to great reserve in respect of accuracy.

4 LUMINANCE OF LIGHT SOURCES

For accuracy in use of the formulae, the light source must be a uniformly bright sphere. Large light sources of other shapes having nearly uniform surface luminance may also be expected to give beam intensity fairly close to the calculated values.

In a fixed directional optical system, the luminance (L) which is to be entered in the formulae of Section A5 is the mean luminance in the direction of the axis of the optical system. In the case of rotating optical panels the axis rotates in the horizontal plane, while in the case of drum lenses there is no defined axis in the horizontal plane. In these cases it is necessary to consider possible variations in light intensity with bearing or to take a mean of effective source luminance at various bearings.

The luminance for any given direction is given by:

$$L = \frac{I}{S}$$

Equation 1 Mean luminance of a source in any given direction

Where:

L = Mean luminance of the source, in cd/m²,

I = Luminous intensity of light source, in the given direction, in candelas,

S = Projected area of light source, in m², on a plane surface normal to the given direction. (This direction will usually be the optical axis).

In general, for complex filament structures, arc discharges of non-uniform luminance, etc., the best that can be done is to take S as the whole area within the smallest convex contour circumscribing the luminous element, even though this area may contain dark spaces within it.

The above method derives the mean luminance, for use in the formulae of Section A5, from a measurement of the luminous intensity of the source. Such a measurement is subject to the general requirements of short-range photometric measurements described in reference [5] but is usually possible, even when measurement on the complete optical system is not possible. In the case of non-uniform light sources, it may be preferable to place the source at the focus of a lens of photographic quality and to make a number of measurements in the beam at various directions close to the optical axis in order to determine the average value of the peak beam intensity. The formulae of Section A5 may then be used to calculate the mean luminance L. This method is essentially an application of the 'ratio-ing' techniques described in Section B.

If this method is used, it is necessary to ensure that the aperture of the lens is fully and reasonably uniformly illuminated. If the light source dimensions are very much less than 1/20 of the focal length of the lens, this may not be possible and the derivation of the mean luminance from measurements on the source alone may be preferable.

When luminous elements of small dimensions are enclosed within a large glass or quartz envelope, there may be difficulty in determining the projected area S. In some cases, the linear dimensions may be measured accurately by the use of a travelling microscope having an objective lens of sufficiently great object distance to permit focusing on the luminous element when the objective is outside the envelope. In the case of arc discharge lamps, it is customary for manufacturers to supply a typical contour diagram of luminance within the discharge. Inspection of this, and of the regions of rapid decrease of luminance with position, may enable a reasonable value of S to be assessed for the discharge. When information of this type is not available, a convenient method of estimation of S may be to use a projection lens of photographic quality to project a focused image of the luminous element on a screen at a convenient finite distance. The measured dimensions of the bright image may be reduced to the corresponding dimensions of the luminous element by multiplying by the ratio of object distance to image distance from the lens. By applying an illumination photometer to the image, information may also be obtained on non-uniform distributions of luminance of the luminous element. In particular, a discharge or a filament may display a

useful length (characterized by high luminance) somewhat less than its actual length obtained by direct measurements.

5 FORMULAE FOR CALCULATION OF PEAK BEAM INTENSITY

The luminous intensity (I_0) at the peak of the beam from a beam projection apparatus which is exhibiting a fixed white light may be calculated from the following formulae in which:

- 1 The term 'net' shall be taken as including only that portion (height or area) of the projection apparatus which is actually illuminated on its emergent face (excepting the bases of the prisms, which are to be included although they will generally be only weakly illuminated). It shall exclude any portion unilluminated because of the intervention of framework or other obstruction, whether between light source and optic or between optic and observer. It shall also exclude dark spaces or areas due to openings in a catoptric or to the separation of the prisms in a catadioptric apparatus.
- 2 The term 'vertical surface' shall be taken as a plane surface normal to the optical axis through the focal point of the beam projection apparatus. In general, lighthouse beams are depressed through a very small angle towards the horizon, but the difference is insufficient to require other terminology.

5.1 PROJECTION APPARATUS FOR A FAN BEAM (GENERATED AROUND A VERTICAL AXIS)

5.1.1 Catoptric

$$I_0 = h_1 d L k_1 c_1$$

Equation 2 Luminous intensity (I_0) at the peak of the beam from a catoptric fan beam projection apparatus

Where:

h_1 = net height of reflectors, in m, projected on to a vertical surface, less the height similarly projected, of any obstruction other than the light source itself, unless it also is obscured.

d = horizontal width of light source, in m

L = luminance of light source, in cd/m^2

k_1 = correction factor depending on the vertical sub-tense angles θ_1 and θ_2 of the mirror, taken from Figure 1. Where there is no obstruction to the beam such as an electric lamp bulb or burner, θ_1 equals zero.

c_1 = effective reflection factor which for the purpose of this formula shall be taken as:

0.9 for vaporized silver or aluminium;

0.8 for silvered glass mirror;

0.75 for lacquered surface-silvered metallic mirrors and anodized aluminium electrolytically brightened mirrors;

0.7 for tin, chromium and rhodium surface-plated mirrors;

0.6 for nickel surface-plated mirrors.

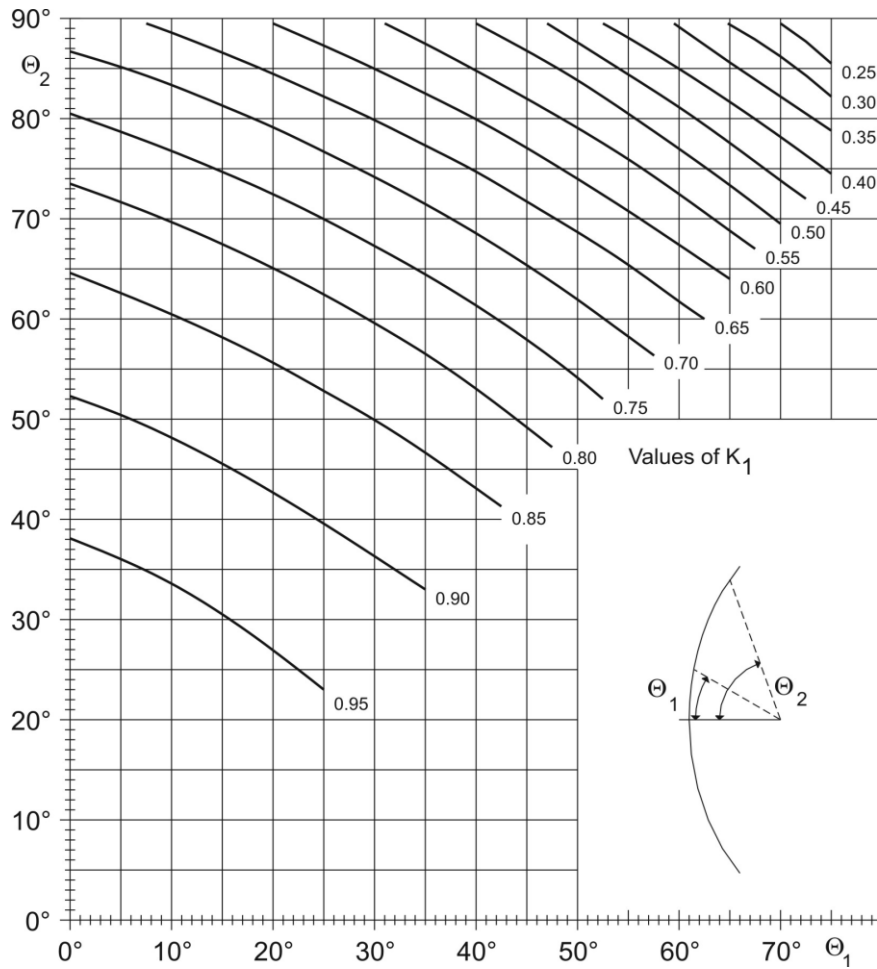

Figure 1 Correction Factor k_1

5.1.2 Dioptric and Catadioptric

$$I_0 = h_2 d L k_2 + h_3 d L k_3 + h_4 d L k_4$$

Equation 3 Luminous intensity (I_0) at the peak of the beam from a dioptric and catadioptric fan beam projection apparatus

Where:

h_2 = net glass height of refractors, in m, projected on to a vertical surface;

h_3 = net glass height of upper reflectors, in m, projected on to a vertical surface;

h_4 = net glass height of lower reflectors, in m, projected on to a vertical surface;

d = horizontal width of light source, in m;

L = luminance of light source, in cd/m^2 ;

k_2 = correction factor depending upon the subtense angle of refractors taken from Figure 2;

k_3 = average correction factor depending upon the appropriate angular limits θ_1 and θ_2 of the upper reflectors calculated from Figure 3;

k_4 = average correction factor depending upon the appropriate angular limits θ_3 and θ_4 of the lower reflectors calculated from Figure 3.

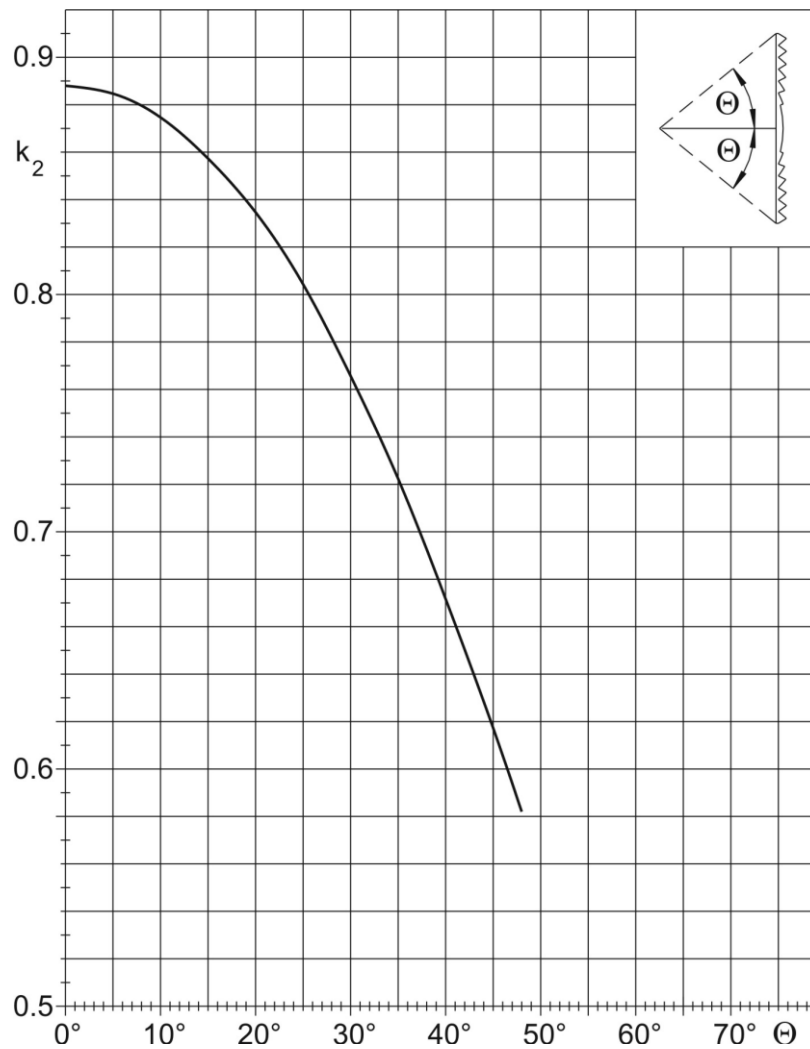

Figure 2 Correction Factors k_2

- Note (1): In the correction factors k_1 to k_4 inclusive, allowance has been made for the variations of the width of the flashed area due to the change of focal distance across the apparatus.
- Note (2): The above formula is to be used for drum lenses having receding catadioptric rings. For drum lenses having a profile in which the lower catadioptric sections are arranged vertically over one another, the value of k_4 should be reduced by 20%.
- Note (3): For smaller drum lenses (dioptric only, and of focal distance 250 mm or less), the following values of k_2 should be used:
- | | |
|------|-------------------------|
| 0.45 | Pressed glass drum lens |
| 0.55 | Cut glass drum lens |
| 0.60 | Moulded acrylic |

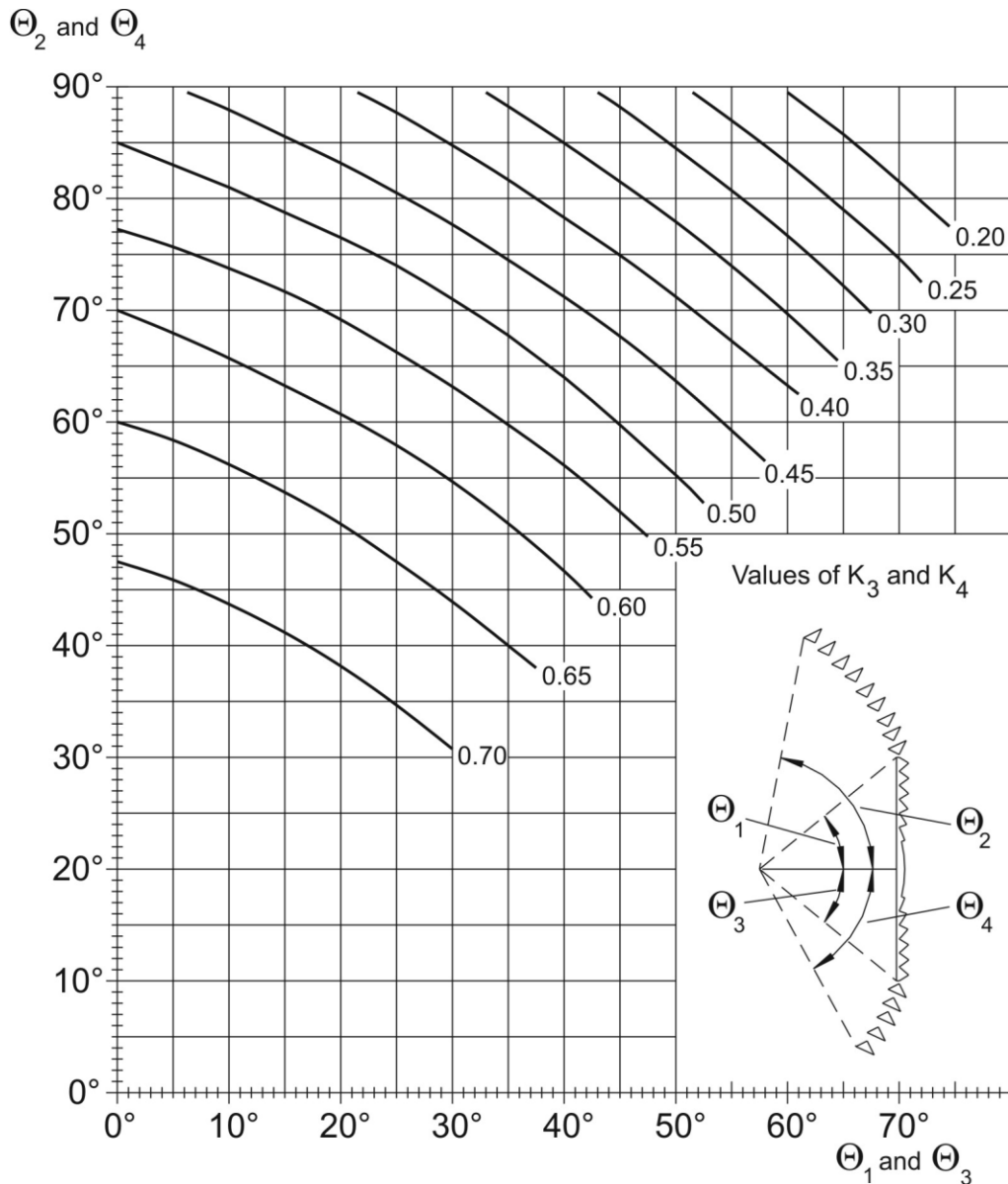

Figure 3 Correction Factors k_3 and k_4

5.2 PROJECTION APPARATUS FOR A PENCIL BEAM

5.2.1 Catoptric

$$I_0 = a_1 L c_1$$

Equation 4 Luminous intensity (I_0) at the peak of the beam from a catoptric pencil beam projection apparatus

Where:

a_1 = net area of mirror, in m^2 , projected on to a plane normal to the direction of concentration, less the area, similarly projected, of any obstruction other than the light source itself unless it also is obscured,

L = luminance of light source, in cd/m^2 ,

c_1 = effective reflection factor which, for the purpose of this formula, shall be as given in Section A5.1.1.

5.2.2 Dioptric and Catadioptric

$$I_0 = a_2 L c_2 + a_3 L c_3$$

Equation 5 Luminous intensity (I_0) at the peak of the beam from a dioptric and catadioptric pencil beam projection apparatus

Where:

a_2 = net glass area of refractors, in m^2 , projected on to a plane normal to the direction of concentration,

a_3 = net glass area of reflectors, in m^2 , projected on to a plane normal to the direction of concentration,

L = luminance of light source, in cd/m^2 ,

c_2 = correction factor depending on the subtense angle of refractors from Figure 4.

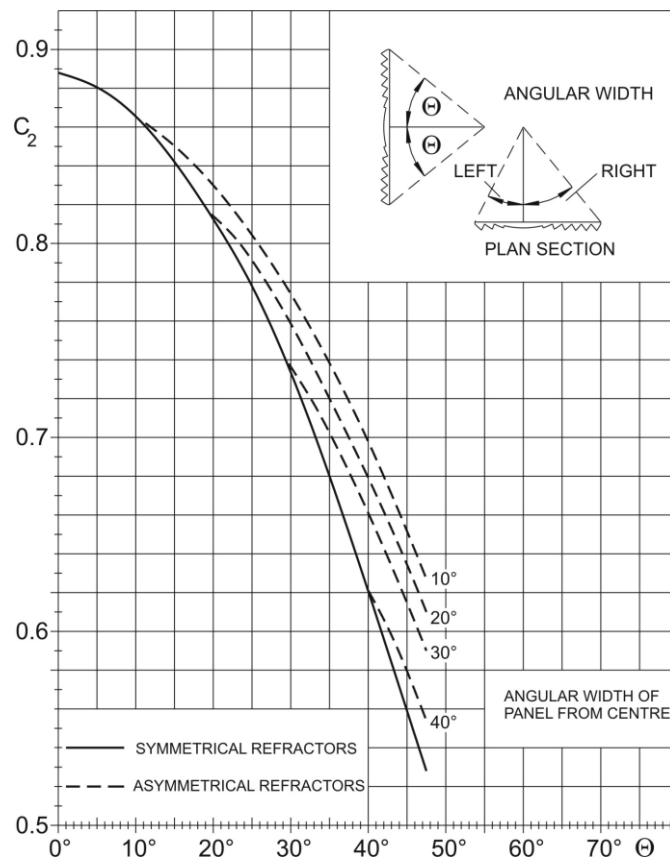

Figure 4 Correction Factor c_2

Where:

$$c_3 = \begin{cases} 0.85 & \text{for receding catadioptric elements} \\ 0.70 & \text{for vertically stacked catadioptric elements} \end{cases}$$

Where the panel is asymmetric the right and left portions of the refractors have to be considered separately and the area of each portion multiplied by the appropriate value of c_2 . The sum of these two quantities when multiplied by L corresponds to the first term on the right hand of the equation.

Note: The above formulae apply with reasonable accuracy to uniform spherical light sources and to large mantle burners. For use with certain types of filament lamp in common use in lighthouse apparatus, the additional

correction factors listed below should be applied. These factors are multipliers for that part of the intensity contributed by the catadioptric elements, and make allowance for the reduction in source luminous intensity in the direction of these elements.

The formula becomes:

$$I_0 = a_2 L c_2 + a_3 p_f L c_3$$

Equation 6 Luminous intensity (I₀) at the peak of the beam from a dioptric and catadioptric pencil beam projection apparatus with filament lamp source

Where:

$$p_f = \begin{cases} 0.9 & \text{for compact coiled – coil filaments} \\ 0.8 & \text{for plane grid filaments} \\ 0.7 & \text{for cylindrical, bunch and cruciform} \end{cases}$$

$$c_3 = \begin{cases} 0.85 & \text{for receding catadioptric elements} \\ 0.70 & \text{for vertically stacked catadioptric elements} \end{cases}$$

For all other sources, including linear coiled-coil filament, filament structures of greater complexity and all discharge lamps, a value of $p_f = 0.5$ should be assumed, unless a coated envelope is used then a value of $p_f = 0.8$ should be used.

Note: By “compact coiled-coil filament” is meant a filament structure consisting of a closely wound coil which is itself wound into a helix of small radius, presenting a compact structure of approximately cylindrical form.

5.2.3 Auxiliary Beams

The luminous intensity of a converged, (or diverged) beam may be derived from that of the initial beam by multiplication by two factors.

One factor is the quotient of the angle of divergence of the beam before convergence (or divergence) by that of the converged (or diverged) beam; the other factor may be taken as 0.9 in the case of auxiliary optical systems made of glass and 0.92 for those made in plastics, to allow for reflection and transmission losses.

The luminous intensity of a diverted beam, changed in direction without change in angle of divergence, is derived from that of the initial beam by multiplying by $(0.9)^n$ for glass systems or $(0.92)^n$ for plastics systems, where n is the number of diverting prisms traversed.

5.3 REINFORCING MIRRORS

5.3.1 Centred Reinforcing Mirrors

When a reinforcing mirror is employed in conjunction with any of the above beam projection apparatus, the intensity of the beam from the reinforced portion of the apparatus is increased and the intensity previously found should be multiplied by the appropriate factor from Table 1:

Table 1 Reinforcing Mirrors Correction Factors

Type of Mirror		Factor
Catoptric	Vaporised silver, silvered glass, lacquered silver on metal or aluminium and anodised aluminium	1.4
	Rhodium or tin surface-plated	1.3
	Chromium or nickel surface-plated	1.2
Catadioptric		1.2

5.3.2 De-centred Reinforcing Mirrors

By employing de-centred reinforcing mirrors with a fan beam it is possible to increase the effective width of the light source over a given arc by forming an image or images to one side of it and so increasing the intensity of the beam over that arc. The increased intensity is given by multiplying the fixed intensity as calculated from Section A5.1.1 by:

$$factor = 1.0 + 0.7 m c_1$$

Equation 7 Increased intensity of a fan beam from de-centred reinforcing mirrors

Where:

m = number of supplementary images (number of de-centred auxiliary mirrors),

c₁ = reflection factor in Section A5.1.1.

6 LIGHT DURATION OF RHYTHMIC BEAMS

6.1 ROTATING APPARATUS

When the beam projection apparatus rotates, the duration of each appearance of light is dependent upon the angle of divergence of the beam and the speed of revolution of the apparatus. If the beam divergence cannot be measured directly, its approximate value may be calculated from the formula:

$$\alpha = \frac{d}{f} [radians] = \frac{180 d}{\pi f} [degrees]$$

Equation 8 Angle of light beam in projection apparatus

Where:

α = angle of divergence,

d = width of light source in the case of horizontal divergence, or height of light source in the case of vertical divergence,

f = focal length of the system.

Consistent units of length must be used.

The width of the light source may be determined as described in Section A0 to above. In the case of a light source with diffused edges (e.g. a frosted lamp or an arc discharge), the width should be taken as that between points at

which the intensity falls to 50% of the peak value. If any other percentage is used, due to previous custom, this should be stated.

The duration of an appearance of light is given by:

$$t = \frac{\alpha}{2 \pi N} = \frac{d}{2 \pi N f}$$

Equation 9 Duration of an appearance of light

Where:

t = duration of the appearance of light,

α = angle of divergence in the horizontal plane, in radians,

N = rate of rotation (number of revolutions per second) of the apparatus,

f = focal length of the system,

d = width of the light source.

6.2 BLANKING SYSTEMS

For a flashing light produced by blanking the light source by the use of an occulting hood, shutter, revolving screen or other mechanical device, the flash duration may be taken as the time interval between the passage of the screen or shutter through its mean position when exhibiting and eclipsing the light respectively. If the time variation of intensity can be measured, the time interval should be taken as that between the instants at which the intensity is 50% of the peak intensity.

6.3 EXTINCTION SYSTEMS

6.3.1 Acetylene and other Gas Flames, and Discharge Lamps

When the beam is eclipsed by a flasher or coder mechanism which interrupts the supply of gas or electricity, the duration of each appearance of light is approximately the duration of the “on” time of the supply. When it is possible to measure the variation of luminous intensity with time directly, the duration of the appearance of light may be taken as the interval between the instants at which the intensity is 50% of the peak intensity.

6.3.2 Incandescent Lamps and Mantle Burners

Owing to the relatively slow thermal response of the filament or mantle, there is a delay in the time course of the luminance of the luminous element with respect to the time of ‘on’ or ‘off’ operation of the flasher or coder mechanism.

Figure 5 shows, for the case of an incandescent filament, the difference between the incandescence time and the nigrescence time, as a function of steady-state filament current. Two curves are given, defined for levels of 90% and 50% of the steady luminous intensity respectively.

The time during which the luminous intensity from the filament exceeds respectively 90% and 50% of steady luminous intensity is given by the contact closure time (i.e. the time during which the supply current is switched on) less the time read from the appropriate curve of Figure 5. If the contact closure time is less than the corresponding time from Figure 5 for 90% level, no guidance can be obtained from the figure, and it is recommended that such short closure times should not be used. If the contact closure time is greater than the time from Figure 5 for 90% level, the flash duration may be taken as contact closure time less the time from Figure 5 for 50% level. This duration may be used in the approximate calculation of effective intensity as in reference [6].

Note: Figure 5 corresponds to the behaviour of lamps operated at rated voltage and with effectively zero circuit resistance.

Underrunning a lamp increases both incandescence and nigrescence times, but the net effect on the correction in Figure 5 is to increase it. If the reduction is of only a few per cent, then in general the effect on the correction will

not be important. The use of Figure 5 may be extended to tungsten-halogen lamps operating at filament temperatures above 3,000° K. The difference of the incandescence and nigrescence times of these lamps from those of ordinary filament lamps is unlikely to be significantly greater than the spread of values of these quantities from lamp to lamp. The use of a series resistance in the external circuit will increase incandescence time (as shown in Figure 11 of B.S. 942: 1949 [29]). The correction in Figure 5 is thereby also increased. The use of a shunt resistance across the circuit switch, to produce a simmering current, will reduce incandescence time and increase nigrescence time. The correction in Figure 5 is thereby decreased. For a simmering current of not more than one quarter of rated current, the correction will not in general be decreased by more than 20%. In the case of doubt as to the magnitude of the correction, it is recommended to measure the time variation of intensity of the switched light source; the optical system need not be used. From the measured curve, the duration of the appearance of light should be taken as that between the instants at which the intensity is 50% of peak intensity. If any other percentage is used, due to previous custom, this should be stated.

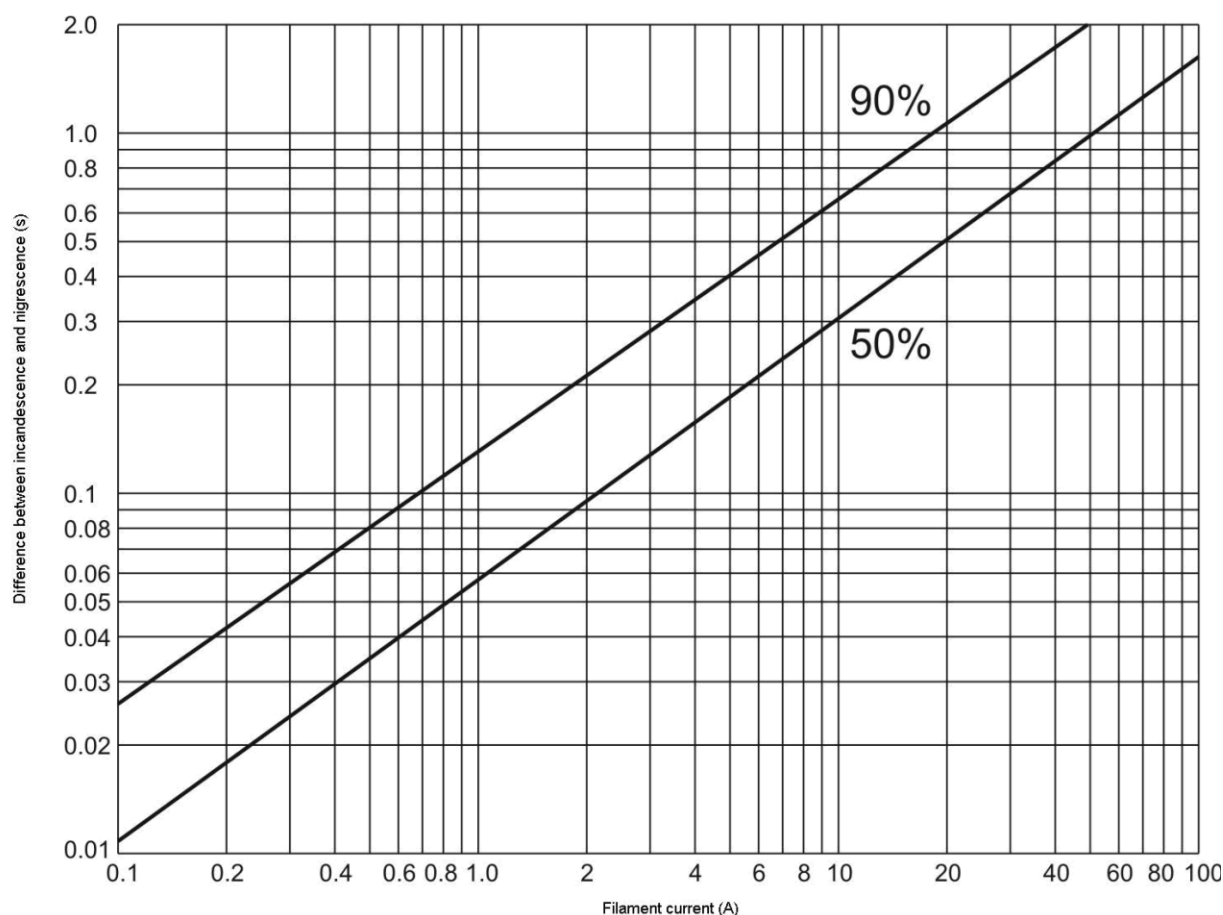

Figure 5 Correction Graph for Incandescence and Nigrescence Time

7 USE OF COLOUR FILTERS

The luminous intensity of a coloured light obtained by the use of a colour filter may be calculated approximately by applying the above methods to derive the luminous intensity of the white light obtained from the optical system in the absence of the filter, and then applying to it the transmission factor of the appropriate filter, which may be separately measured. If transmission factor measurements on the colour filter to be used in an installed light are not available, approximate luminous intensity may be found by the use of the appropriate value from the table below, which shows typical average values of percentage transmission factor of colour filters made in glass or dyed plastics.

Table 2 Average Transmission Factors of Coloured Filters

Light Source	Colour Temperature or Correlated Colour Temperature	Colour of Filter (Glass & Plastics)			
		Red	Green	Yellow	Blue
		Transmittance (%)			
Acetylene Gas (Open Flame)	≈ 2500 K	25	35	75	-
Tungsten Incandescent	≈ 2750 K	22	32	70	-
Tungsten Halogen Incandescent	≈ 3000 K	20	35	65	-
Mercury Discharge	≈ 3900 K	12	35	65	-
Xenon Discharge	≈ 6000 K	13	18	-	3
White PC LED	≈ 8300K	6	13	-	6

It should be noted that with some colour filters, particularly those which give greater certainty of colour recognition, transmission factors may be significantly lower than those given in the table. It is therefore recommended that, as far as possible, values of transmission factor of colour filters should be measured. It is important to determine the resultant colour of the light source and filter combination to ensure that it falls within recommended boundaries (see reference[3]). This should be done where possible by colour measurement (see reference [5]).

8 METHODS OF DEDUCING ATMOSPHERIC TRANSMISSION FROM LIGHTHOUSE OBSERVATION

There are details of how to determine local atmospheric conditions given in B.S. 942 (1941). At one time, it was usual to observe neighbouring lighthouses and to record the number of nights on which the light can be seen. As an example, a lighthouse with a light having an apparent intensity of 960,000 candles has been observed with the following results:

Table 3 Percentage Frequency of Observing Neighbouring Lighthouses

From	Position						
	1	2	3	4	5	6	
Distance in nautical-miles	7	10	13	16	21	21	
Percentage frequency of seeing:	1937	85	82	80	65	58	51
	1938	94	84	84	72	65	55

From the formula:

$$I = \frac{E x^2}{T^x}$$

Equation 10 Intensity of a light from atmospheric transmission

By taking logarithms it may be shown:

$$-\log T = \frac{\log I - \log(E x^2)}{x}$$

Equation 11 Atmospheric transmission from observations from neighbouring lighthouses

and the several atmospheric transmission factors calculated for the condition when the light is just seen are:

*0.230 0.385 0.500 0.583 0.681 0.681

A curve can be drawn with transmission factors as abscissae and percentage frequencies as ordinates (Figure 6) and from this the value of T corresponding to any frequency can be deduced. The spread of results is usually high and as many readings as possible should be made.

Owing to variations of atmospheric transmission, the luminous range of a light is liable to extensive variation and in selecting the value for T for any locality the average atmospheric conditions for that locality should be assessed, and persistent local mist, winds laden with smoke from an industrial area, mensual variation and such like circumstances should be taken into account.

Where there is neighbouring shore light the illuminance level may require to be higher than 0.2 μ Lux and a suitable value for E should be chosen in such cases (see reference [4]).

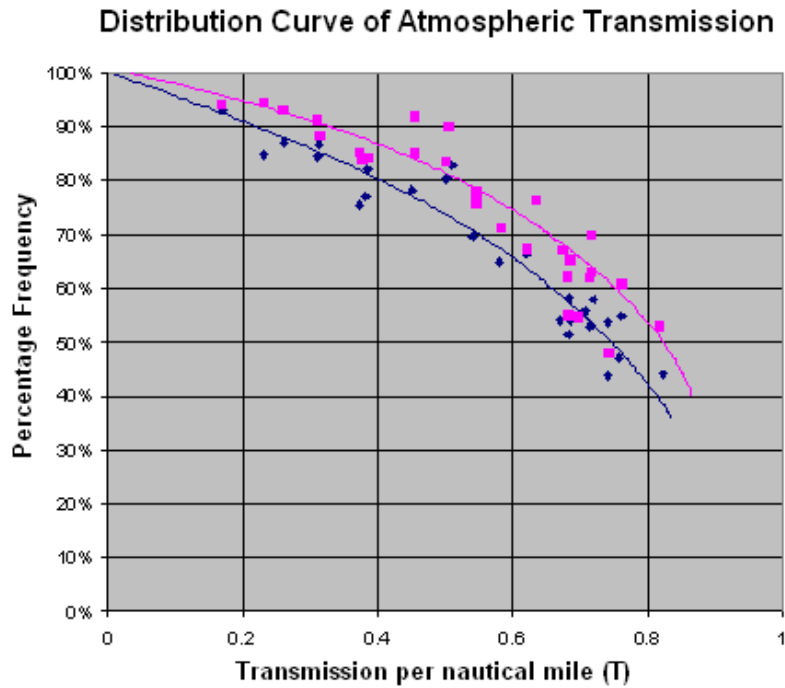

Figure 6 Distribution Curve of Atmospheric Transmission

*This means, for example, in position 1 that the atmospheric transmission factor was 0.23 per nautical-mile or greater on 85 per cent of the occasions in 1937, or 94 per cent of the occasions in 1938.

9 EFFECT OF LANTERN GLAZING AND SERVICE CONDITIONS FACTOR

The formulae given above give approximate beam luminous intensities at emergence from the beam projection apparatus. When such apparatus is housed in a lantern, calculated intensities should be reduced by a factor. It is recommended that the factor be taken as 0.85 (15%) for a system in clean condition. The factor to cover practical service conditions may also be applied. It is recommended that this factor be taken as 0.75 (25%); this should be stated clearly in any calculation (see also reference [4]).

10 LIMITATIONS OF THE CALCULATIONS

The accuracy of the results obtained from the above calculations is very limited, being of the order of $\pm 20\%$ for a uniform spherical light source (approximated by a mantle burner). For light sources of other shapes, particularly planar filaments and discharge lamps, the accuracy becomes very much lower in an unpredictable way. The calculations are intended only for use when no other method of estimating beam intensity is available.

When it is required to estimate the beam intensity for a given source-optic combination on which direct measurements cannot be made, it may be that measured data are available for the same optic with other sources, or for the same source with other optics. In such cases, a better estimate of beam intensity may possibly be obtained by methods described in Section B.

EXAMPLE 1 - The following is an example of how to calculate the peak intensity, effective intensity, flash duration and character, using the methods described, for a second order (0.7m focal length) rotating lens (at 3RPM) with a 400W metal halide clear envelope lamp as the light source (kindly provided by Trinity House).

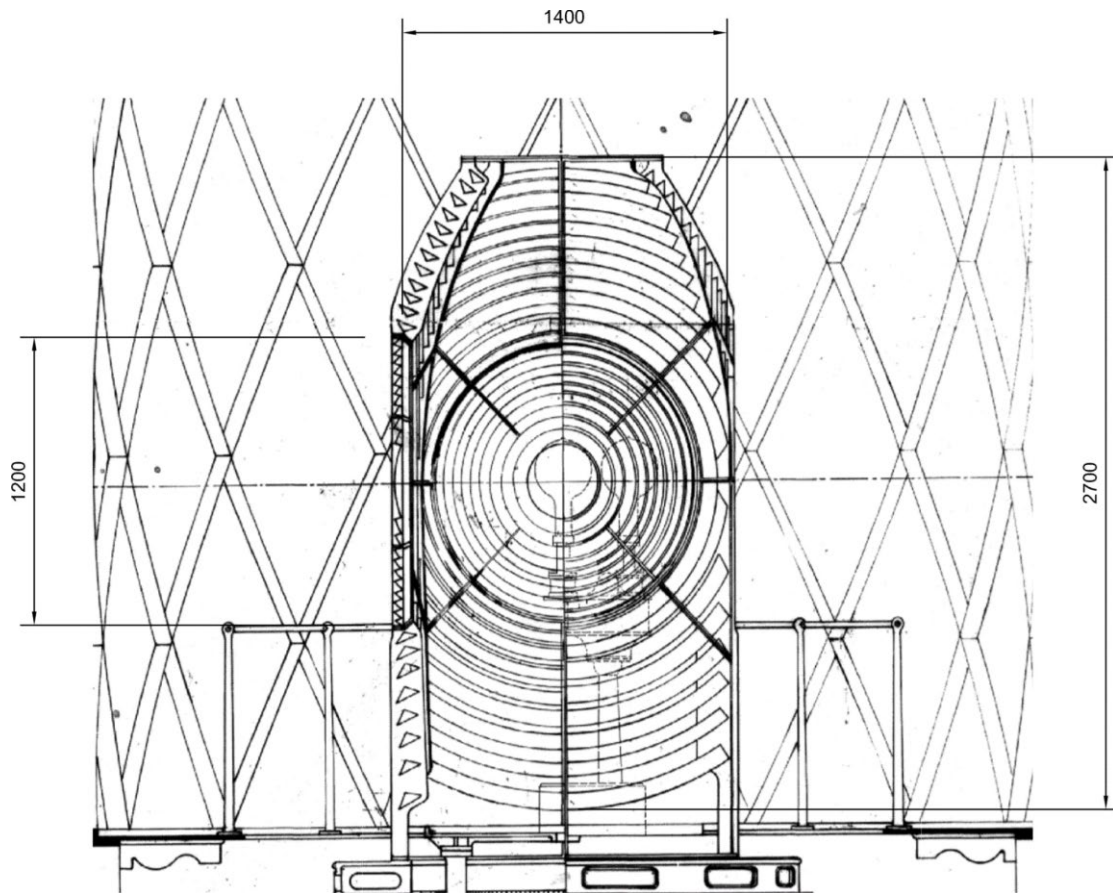

Figure 7 Example 1 – Drawing of 2nd Order Rotating Optic

Using 0 from Section A0

$$L = \frac{I}{S}$$

Where:

L = Mean luminance of the source, in cd/m²

I = Luminous intensity of light source, in the given direction, in candelas

S = Projected area of light source, in m², on a plane surface normal to the given direction. (This direction will usually be the optical axis.)

From the formula:

$$I = \frac{\Phi}{4\pi}$$

Equation 12 Luminance intensity of light source

Where:

I = Luminous intensity of light source, in the given direction, in candelas,

Φ = Total luminous output from a light source, in lumens.

From the manufacturers data sheet: the lamp is quoted as having a luminous output of 32,000 lumens and lit dimensions of 40mm(h) and 10mm(w) giving a lit area (S) of 0.0004m².

$$I = \frac{32,000}{12.57} \text{ cd} = 2,546 \text{ cd}$$

Therefore:

$$L = \frac{2,546}{0.0004} \text{ cd/m}^2 = 636,500 \text{ cd}$$

From the diagram above the areas of the refractors and the reflectors can be calculated as:

- Total area of refractors = 1.2m x 1.4m = 1.68m²,
- Area of upper reflectors = 0.78m² (Calculated from Electronic drawing),
- Area of lower reflectors = 1.02m² (Calculated from Electronic drawing),
- Total lens area = 1.68 + 0.78 + 1.02 = 3.48m².

Using 0 from Section A0:

$$I_0 = a_2 L c_2 + a_3 p_f L c_3$$

Where:

- a₂ = 1.68m²,
- L = 6,365,000cd/m²,
- C₂ = 0.62 (400),
- a₃ = 1.8m²,
- p_f = 0.5 (for a discharge lamp),
- L = 6,365,000cd/m²,
- C₃ = 0.8 (as only the upper reflectors are receding).

$$I_0 = (1.68 \cdot 6,365,000 \cdot 0.62) \text{ cd} + (1.8 \cdot 0.5 \cdot 6,365,000 \cdot 0.8) \text{ cd} = 11,211,456 \text{ cd}$$

Using the 0 from Section 6.1 the flash duration can be calculated as follows:

$$t = \frac{\alpha}{2 \pi N} = \frac{d}{2 \pi N f}$$

Where:

- t = duration of the appearance of light,
- α = angle of divergence in the horizontal plane, in radians,
- N = rate of rotation (number of revolutions per second) of the apparatus,
- d = width of light source in the case of horizontal divergence, or height of light source in the case of vertical divergence,
- f = focal length of the system.

$$t = \frac{0.01}{2 \pi \left(\frac{3}{60}\right) 0.7} \text{ s} = 0.05 \text{ s}$$

Using the following formula the effective intensity can be calculated. For further information regarding effective intensity see reference [6].

$$I_e = \frac{I_0 t}{(0.2 + t)}$$

$$I_e = \frac{11,211,456 \cdot 0.05}{(0.2 + 0.05)} \text{ cd} = 2,242,291 \text{ cd}$$

Allowing for a service conditions factor of 0.75 and a further factor of 0.85 for glazing losses gives:

$$I_e = 1,429,460 \text{ cd}$$

This gives a nominal range of **27M**

Measured intensity of the above configuration varied by panel from 1,100,000cd to 1,200,000cd. Comparing the calculation to the measured data, the calculation over estimates the result by approximately 20%.

EXAMPLE 2 - The following is an example of how to calculate the peak intensity, effective intensity, flash duration and character, using the methods described, for a fourth order optic with four asymmetrical rotating lens (at 1.5RPM) with a 100V 1000W lamp as the light source (kindly provided by the Northern Lighthouse Board).

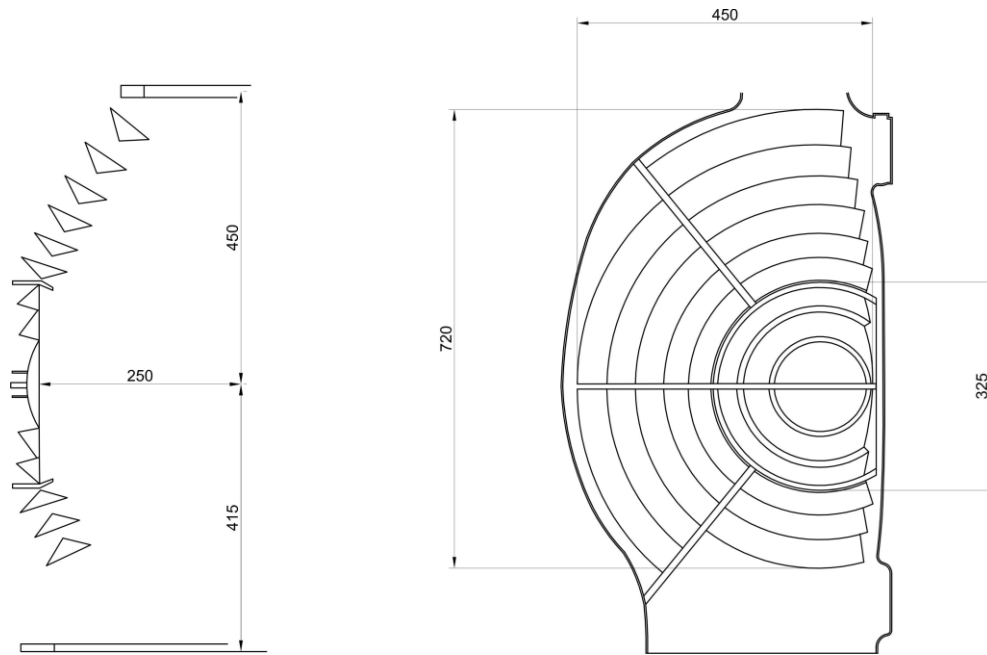

Figure 8 Drawing of a 4th Order Optic

From the 'Specification for electric lamps for lighthouses BS:1546 data sheet, the lamp is quoted as having an average luminance of 6,000,000 cd/m²

Therefore:

$$L = 6,000,000 \text{ cd} / \text{m}^2$$

From the diagram above the areas of the refractors and the reflectors can be calculated as:

- Total area of refractors = 0.065m² (Calculated from Electronic drawing),
- Area of upper reflectors = 0.121 m² (Calculated from Electronic drawing),
- Area of lower reflectors = 0.077 m² (Calculated from Electronic drawing),
- Total lens area = 0.263m².

Using 0 from Section A0

$$I_0 = a_2 L c_2 + a_3 p_f L c_3$$

Where:

- $a_2 = 0.065\text{m}^2$,
- $L = 6,000,000\text{cd}/\text{m}^2$,
- $C_2 = 0.7 (33^\circ)$,
- $a_3 = 0.198\text{m}^2$,
- $p_f = 0.5$ (for a discharge lamp),
- $L = 6,000,000\text{cd}/\text{m}^2$,
- $C_3 = 0.85$ (as reflectors are receding).

$$I_0 = (0.065 \cdot 6,000,000 \cdot 0.7)cd + (1.198 \cdot 0.5 \cdot 6,000,000 \cdot 0.85) cd = 777,900 cd$$

Using 0 in Section A6.1 the flash duration can be calculated as follows:

$$t = \frac{\alpha}{2 \pi N} = \frac{d}{2 \pi N f}$$

Where:

- t = duration of the appearance of light,
- α = angle of divergence in the horizontal plane, in radians,
- N = rate of rotation (number of revolutions per second) of the apparatus,
- d = width of light source in the case of horizontal divergence, or height of light source in the case of vertical divergence,
- f = focal length of the system.

$$t = \frac{0.02}{2 \pi \left(1.5/60\right) 0.25} s = 0.5 s$$

$$I_e = \frac{I_0 t}{(0.2 s + t)}$$

$$I_e = \frac{777,900 \cdot 0.5}{(0.2 + 0.5)} cd = 558,555 cd$$

Allowing for a service conditions factor of 0.75 and a further factor of 0.85 for glazing losses, gives:

$$I_e = 356,079 cd$$

=

This gives a nominal range of **23M**

The measured intensity of the above configuration for the lowest panel was 319,000cd. Comparing the calculation to the measured data, the calculation over estimates the result by approximately 10%.

SECTION B - ESTIMATION OF BEAM INTENSITY BY RATIO-ING TECHNIQUES

1 PURPOSE

This section is intended as a guide to estimation of the luminous intensity and angle of divergence of the beam from various types of beam projection apparatus when data can be obtained by direct measurement on similar but not identical combinations of light source and optical system. The methods described are referred to as comparison or 'ratio-ing' techniques.

Accuracy of results obtained by using ratio-ing techniques is only as good as the first-order geometrical relations which they represent. The precision of the results is limited by inaccuracies in the assumptions made. However, the ratio-ing technique is to be preferred to that of direct computation, of the type given in Section A. There is less likelihood of error in an estimation of optical performance based on comparisons between source/optic combinations of similar design where measurements are available for one such design, than in estimation of performance for a new combination.

Similar optical systems can be scaled, within reasonable limits, to predict performance with more confidence than can be placed in the use of the formulae given in Section A.

2 EXAMPLES OF ESTIMATION OF LUMINOUS INTENSITY

2.1 FIXED LENSES

2.1.1 Change of Source

It is required to find the luminous intensity of the fan beam produced by a fixed lens when used with a light source of luminance L and width d . The luminous intensity is assumed to have been measured for an identical fixed lens with a light source of luminance L' and width d' , and has been found to be I' .

From 0 in Section A 5.1.2

$$I' = h_2 d' L' k_2 + h_3 d' L' k_3 + h_4 d' L' k_4$$

and the required intensity is

$$I = h_2 d L k_2 + h_3 d L k_3 + h_4 d L k_4$$

Hence:

$$\frac{I}{I'} = \frac{d L}{d' L'}$$

2.1.2 Change of Fixed Lens Size

In this case the intensity is assumed to have been measured for an identical light source in a fixed lens of different focal length and dimensions but with the same, or nearly the same, relative areas and angular subtense of dioptric, upper and lower catadioptric portions. Thus, the coefficients k_2 , k_3 , and k_4 are virtually unaltered, and the heights of the various portions of the unknown system may be taken as a constant (say p) times the corresponding heights of the measured system.

From Section A 5.1.2

$$\frac{I}{I'} = \frac{h_2 d L k_2 + h_3 d L k_3 + h_4 d L k_4}{h_2 d' L' k_2 + h_3 d' L' k_3 + h_4 d' L' k_4}$$

Equation 13 Intensity of similar lens with same light source using comparison method

Such that the intensity is scaled directly as the linear dimensions of the fixed lens.

2.2 OPTICAL PANELS

2.2.1 Change of Source

In this case, using 0 from Section A0

$$I' = a_2 L' c_2 + a_3 L' c_3$$

and the required intensity is

$$I = a_2 L c_2 + a_3 L c_3$$

so that

$$\frac{I}{I'} = \frac{L}{L'}$$

Equation 14 Intensity scaled from luminance of the light source

and the intensity is scaled directly as the luminance of the source.

Where:

I = Measured Intensity (cd),

I' = Ratio-ed Intensity (cd),

L = Calculated Luminance of original lamp,

L' = Calculated Luminance of replacement lamp.

EXAMPLE B1 – From example A1. The 400W lamp has been replaced by a similar 400W metal halide, as follows:

$$\frac{I}{I'} = \frac{L}{L'}$$

Where:

I = Measured Intensity (cd),

I' = Ratio-ed Intensity (cd),

L = Calculated Luminance of original 400W lamp,

L' = Calculated Luminance of replacement 400W lamp.

From manufacturer's data, the luminance of the replacement lamp was calculated to be:

$$2864/0.0007 \text{ cd/m}^2 = 4,091,374 \text{ cd/m}^2$$

The measured intensity of the optic in example 1 was 2,171,000 cd.

Therefore:

$$\frac{2,171,000}{I'} = \frac{6,365,000}{4,091,374}$$

$$I' = \frac{2,171,000}{1.56} \text{ cd} = 3,377,111 \text{ cd}$$

Measured intensity of the replacement 400W metal halide was 3,045,000cd. Comparing the calculation to the measured data, the calculation under-estimates the result by approximately 10%.

EXAMPLE B2 – From example A2. The 1000W lamp has been replaced by a 250W Metal Halide, as follows:

$$\frac{I}{I'} = \frac{L}{L'}$$

Where:

I = Measured Intensity (cd)

I' = Ratio-ed Intensity (cd),

L = Calculated Luminance of original 1000W lamp,

L' = Calculated Luminance of replacement 250W lamp.

Therefore:

$$\frac{I}{I'} = \frac{6,000,000}{5,507,246} = 1.09$$

and, since the measured intensity of the optic was 319,000cd:

$$I = \frac{319,000}{1.09} \text{ cd} = 292,800 \text{ cd}$$

Measured intensity of the 250W metal halide was 364,000cd. Comparing the calculation to the measured data, the calculation under-estimates the result by approximately 20%. This is typical for metal halide lamps as the arc tube emits an uneven luminance.

2.2.2 Change of Optical Panel Size

In this case, measurements of intensity are assumed to have been made on a combination consisting of an identical source with an optical panel of different dimensions but having approximately the same relative areas and angular subtense angles for the various dioptric and catadioptric portions. (This will apply to panels of different focal length with all dimensions scaled proportionally, or to panels of similar section but extended over different ranges of azimuth angle.)

The coefficients c_2 and c_3 are thus virtually unchanged, and the areas of the various portions of the unknown panel may be taken as a constant (say q) times the corresponding areas of the measured panel.

From 0 in Section A0

$$\frac{I}{I'} = \frac{a_2 L_{c_2} + a_3 L_{c_3}}{a'_2 L_{c_2} a'_3 L_{c_3}} = q$$

such that the intensity is scaled directly as the area of the optical panel.

Note 1. The beam intensities referred to in the above calculations are *uncorrected beam intensities* corresponding to steady light intensities measured for the source/optic combination alone, at rated lamp voltage. They make no allowance for glazing losses, effects of supply voltage variation or visual effects of flashing lights.

Note 2: Application of the ratio-ing technique to optical systems of somewhat different shape, so that the constants k and c are not unchanged, is possible within limits, provided that care is exercised to avoid unduly gross approximations.

3 EXAMPLES OF ESTIMATION OF BEAM DIVERGENCE

According to 0 in Section A.6.1, the beam divergence in radians may be calculated as:

$$\alpha = \frac{d}{f}$$

The uncertainties in estimating the proper value for the source dimension d make the ratio-ing technique the preferred method of estimation of divergence when photometric data is available for an identical light source in a similar optical system of different focal length.

If, for this second system, the divergence has been found to be α' , and the focal length of the system is f' , then from 0:

$$\alpha' = \frac{d}{f'}$$

The required divergence is therefore obtainable from:

$$\frac{\alpha}{\alpha'} = \frac{f'}{f}$$

The use of this technique often gives significantly better agreement with measured values than does the method of direct calculation.

3.1 SCALING OF FLASH DURATION

Using 0 from Section 6.1, for a rotating optic at a rotation speed N rev/s, the divergence α is related to the flash duration t by

$$t = \frac{\alpha}{2 \pi N}$$

Suppose that it is required to find the flash duration for an optic of focal length f and rotation speed N. It has been found that a similar optic of focal length f' and rotation speed N' gives a flash duration t' . Then the required flash duration t is obtained from.

$$t = \frac{\alpha' N'}{\alpha N} t'$$

Equation 15 Flash duration using comparison method

Where

- α is the divergence of the subject optic,
- α' is the similar comparison optic,
- N is the rotation speed of the subject optic,
- N' is the rotation speed of the similar comparison optic
- t is required flash duration,
- t' is flash duration of the similar comparison optic.



For rotating optical systems with fairly large light sources giving smooth distributions of intensity, changes in rotation speed or focal length result in changes of flash duration without change in flash shape. By the use of the above expression, measured data for one such system may be scaled to yield flash durations for a wide range of similar optical systems of different focal lengths and/or rotation speeds. By application of the methods of Section C, tables or graphs of the ratio of effective intensity to peak intensity can be deduced over the whole range.

4 CONCLUSIONS

Estimation of beam intensities and divergences are at best a rough approximation of performance and should only be used when direct measurement cannot be carried out. Where possible, estimations made in this recommendation should be confirmed by direct measurement (see reference [5]). Nevertheless, estimation by the methods described herein is a useful tool in the design and modification of marine AtoN signal lights, especially in view of obsolescence and improved light sources available in today's market.

Where possible, methods described in Section B should be used in preference to those described in section A, since they offer greater accuracy.

5 REFERENCES

- [1] IALA Recommendation on the determination of luminous intensity of a marine Aid-to-Navigation light, December 1977.
- [2] British Standard BS942, 1949.
- [3] IALA Recommendation R0201 (E-200-1) on Marine Signal Lights Part 1 – Colours (E200-1).
- [4] IALA Recommendation R0202 (E-200) on Marine Signal Lights Part 2 - Calculation, Definition and Notation of Luminous Range (E200-2).
- [5] IALA Recommendation R0203 (E200-3) on Marine Signal Lights Part 3 – Measurement (E200-3).
- [6] IALA Recommendation R0204 (E-200-4) on Marine Signal Lights Part 4 - Determination and Calculation of Effective Intensity (E200-4).