

Display of e-Navigation information

Where do we display all this new information?

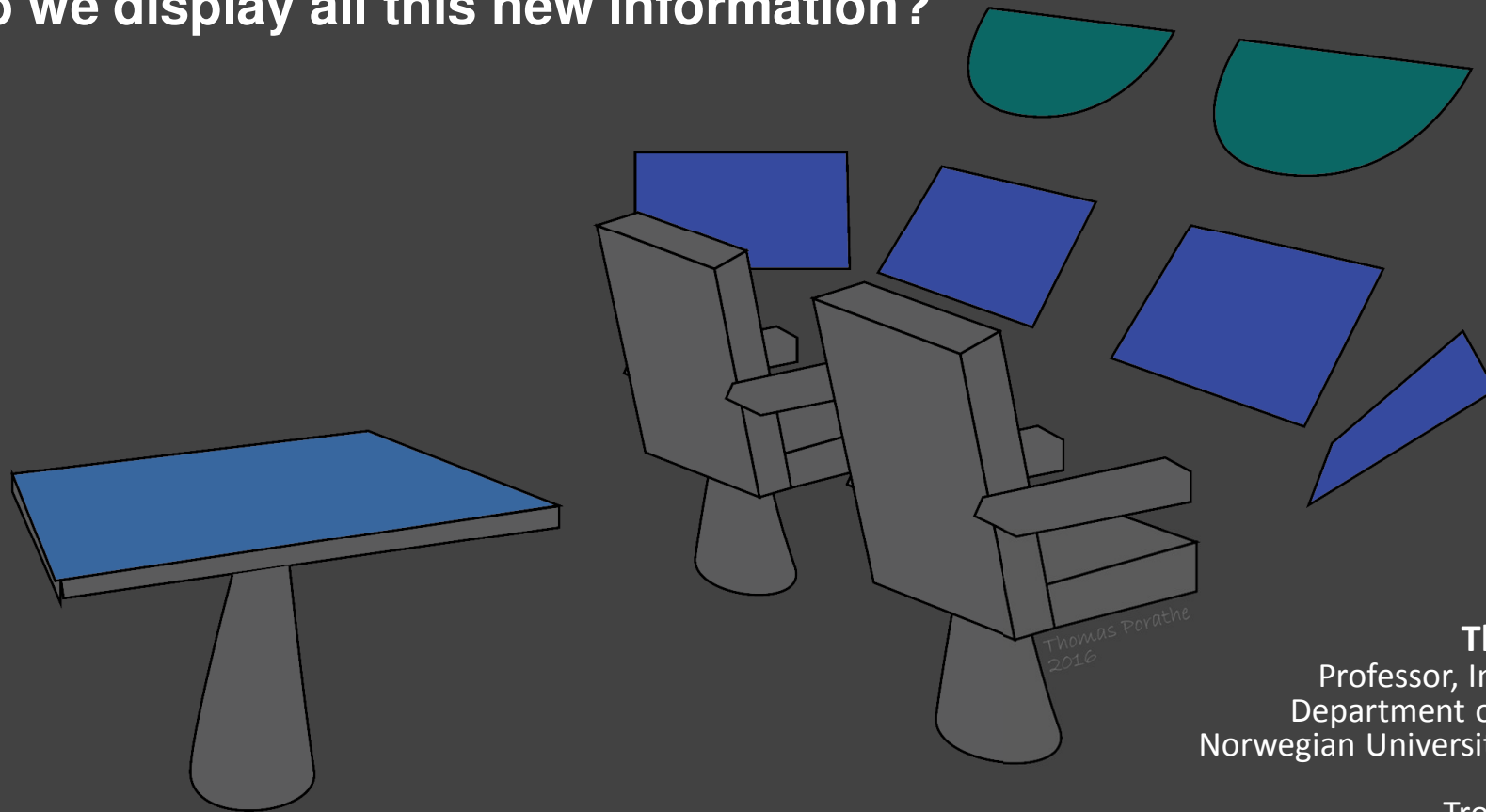

Thomas Porathe
Professor, Interaction design
Department of Product design
Norwegian University of Science and
Technology
Trondheim, Norway

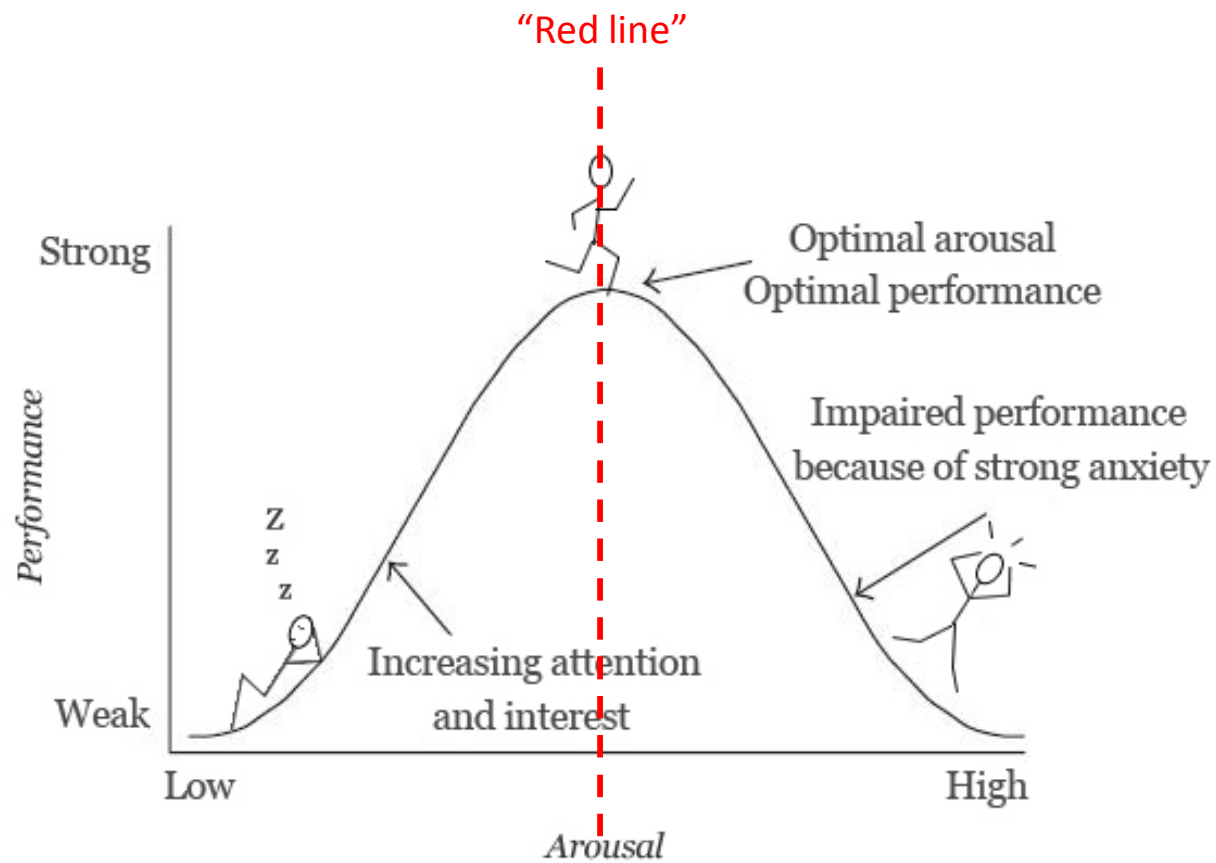

The Yerkes–Dodson law

Stress Component Effects (passing the “Red line”)

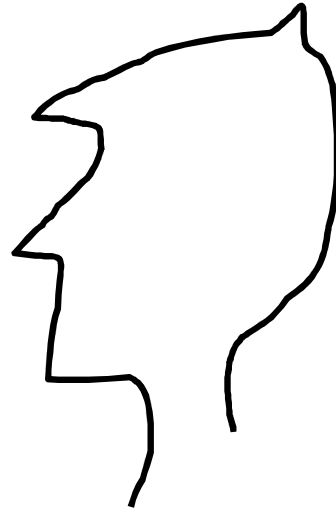
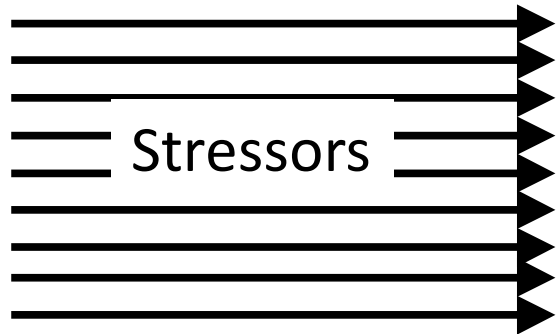

Coping techniques

- Recrute ressources (“try harder”)
 - Remove stressors
 - Strategic adaptation (change goals)
 - Do nothing
-
- Selective attention (“tunnelling”)
 - Working memory loss
 - Preservation (confirmation bias)
 - Coping

Stress Remediation

- Environmental solutions (e.g. remove noise)
- Personal solutions (e.g. training)
- Design solutions:
 - Decluttering (attention narrowing)
 - Organisation of information (unsystematic scanning)
 - Move from textual to graphic presentation (faster parallel processing)
 - Minimize need to keep info in memory
 - Compatibility between response and mental model (Ecological Interface Design)
 - Design of emergency procedures
 - Avoid arbitrary symbols

MSPs	Information items
1 IS	<ul style="list-style-type: none"> • The position, identity, intention and destination of vessels; • Amendments and changes in promulgated information concerning the VTS area such as boundaries, procedures, radio frequencies, reporting points; • The mandatory reporting of vessel traffic movements; • Meteorological and hydrological conditions, notices to mariners, status of aids to navigation; • Maneuverability limitations of vessels in the VTS area that may impose restrictions on the navigation of other vessels, or any other potential hindrances: or • Any information concerning the safe navigation of the vessel.
2 NAS	<ul style="list-style-type: none"> • Risk of grounding; • Vessel deviating from the recommended track or sailing plan; • Vessel unsure of its position or unable to determine its position; • Vessel unsure of the route to its destination; • Assistance to a vessel to an anchoring position; • Vessel navigational or maneuvering equipment casualty; • Inclement conditions (e.g. low visibility, high winds); • Potential collision between vessels; • Potential collision with a fixed object or hazard; • Assistance to a vessel to support the unexpected incapacity of a key member of the bridge team, on the request of the master.
3 TOS	<ul style="list-style-type: none"> • vessel movements need to be planned or prioritized to prevent congestion or dangerous situations; • special transports or vessels with hazardous or polluting cargo may affect the flow of other traffic and need to be organized; • an operating system of traffic clearances or sailing plans, or both, has been established; • the allocation of space needs to be organized; • mandatory reporting of movements in the VTS area has been established; • special routes should be followed; • speed limits should be observed; • the VTS observes a developing situation and deems it necessary to interact and coordinate vessel traffic; • nautical activities (e.g. sailing regattas) or marine works in-progress (such as dredging or submarine cable-laying) may interfere with the flow of vessel movement.
4 LPS	<ul style="list-style-type: none"> • berthing information; • availability of port services; • shipping schedules; • meteorological and hydrological data.
5 MSI	<ul style="list-style-type: none"> • National Hydrographic Offices, for navigational warnings and chart correction data; • National Meteorological Offices, for weather warnings and forecasts; • Rescue Co-ordination Centres (RCCs), for shore-to-ship distress alerts; • The International Ice Patrol, for Oceanic ice hazards.

... and 11+ more...

Integrated
Navigation
System
(INS)



M/V Kong Harlad

thomas.porathe@ntnu.no

“Back bridge”
2015

P&O North Sea Ferries' M/V Pride of Hull

thomas.porathe@ntnu.no

 NTNU

Worst case

Unintegrated
Stand Alone
ECDIS



thomas.porathe@ntnu.no



Captain Jason Ikiadis, right, and First Officer Nikos Ninios on the bridge of the Azamara Journey. (Photo Eric Wynne)

<http://thechronicleherald.ca/titanic/slideshow/83244-azamara-journey>

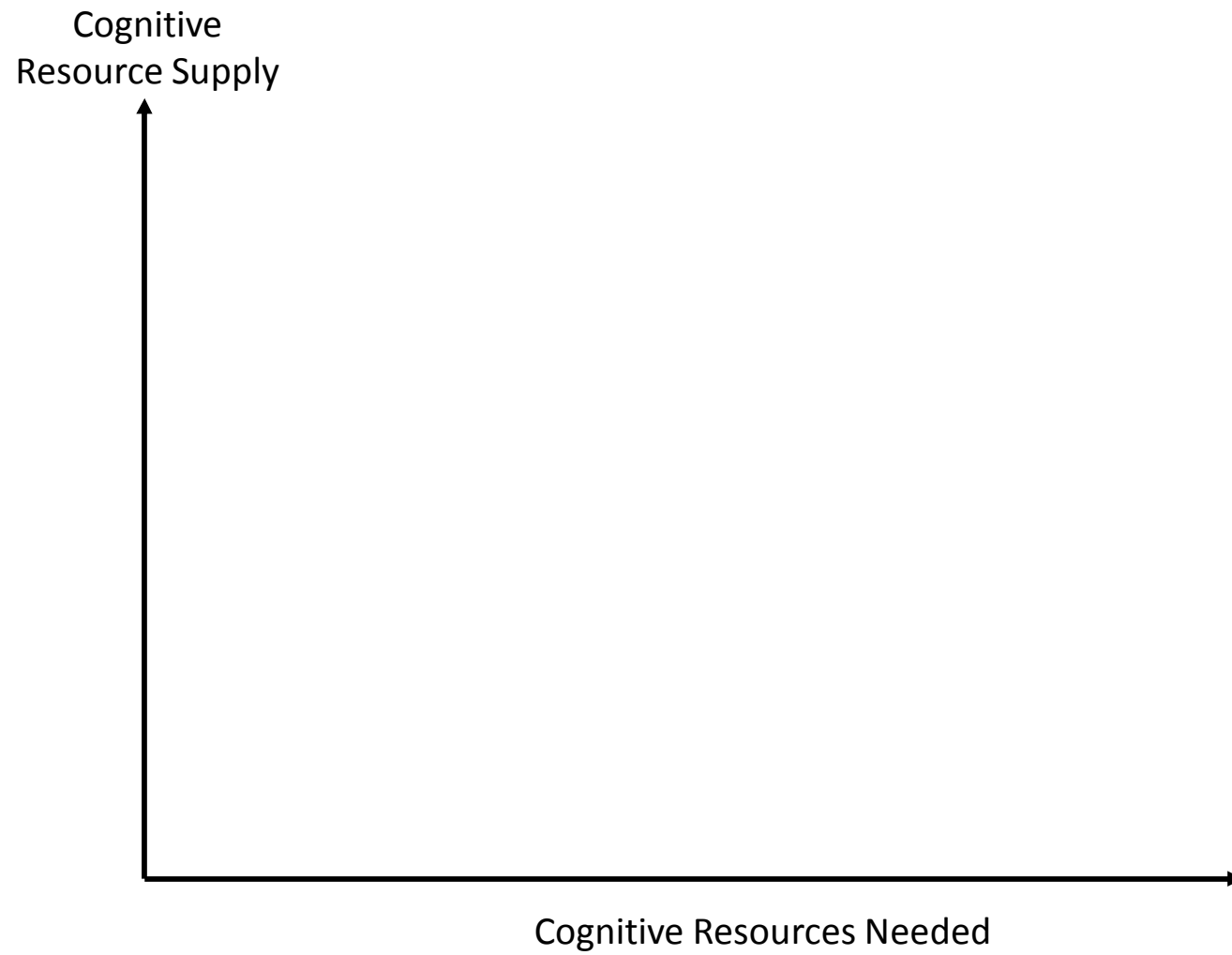

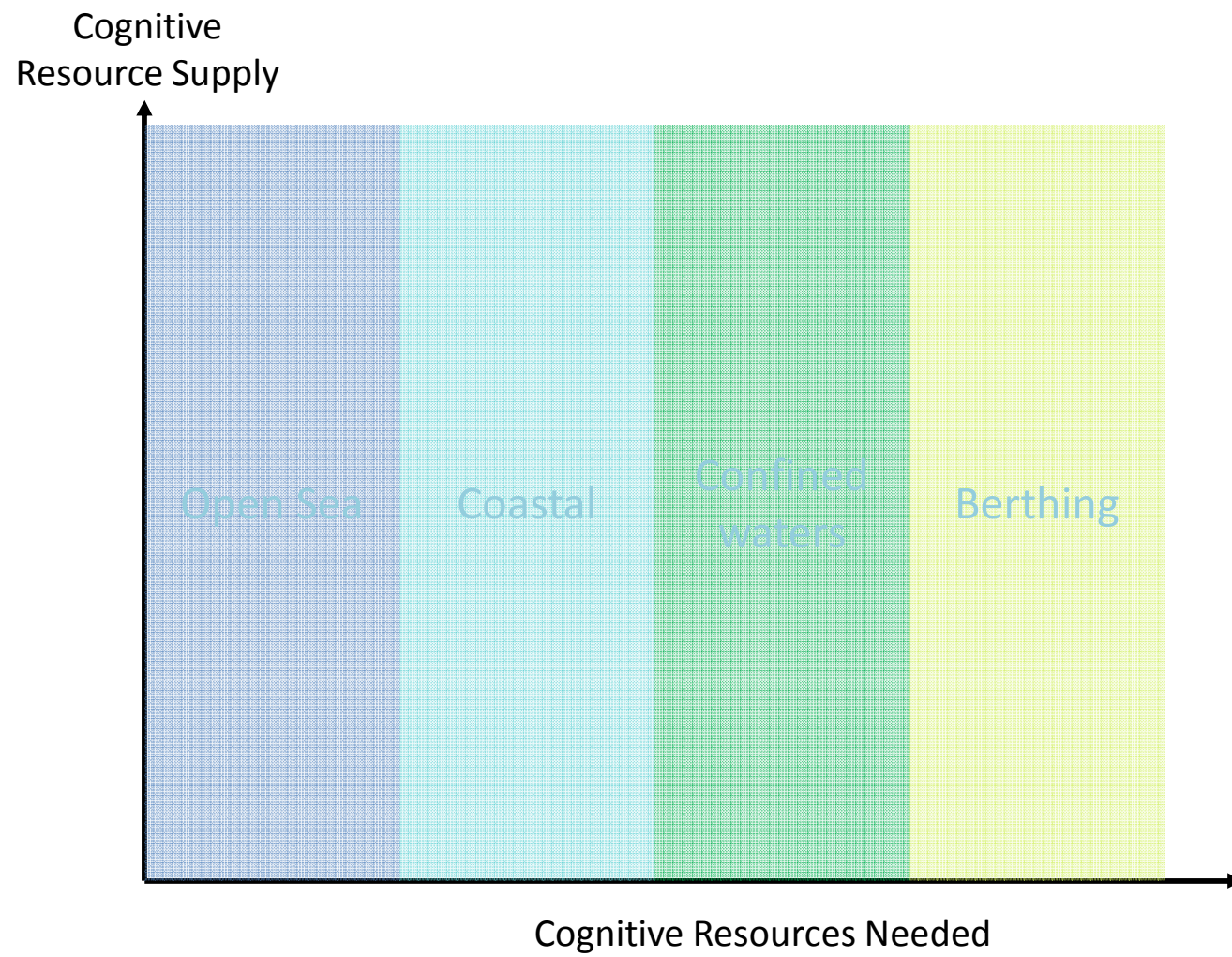

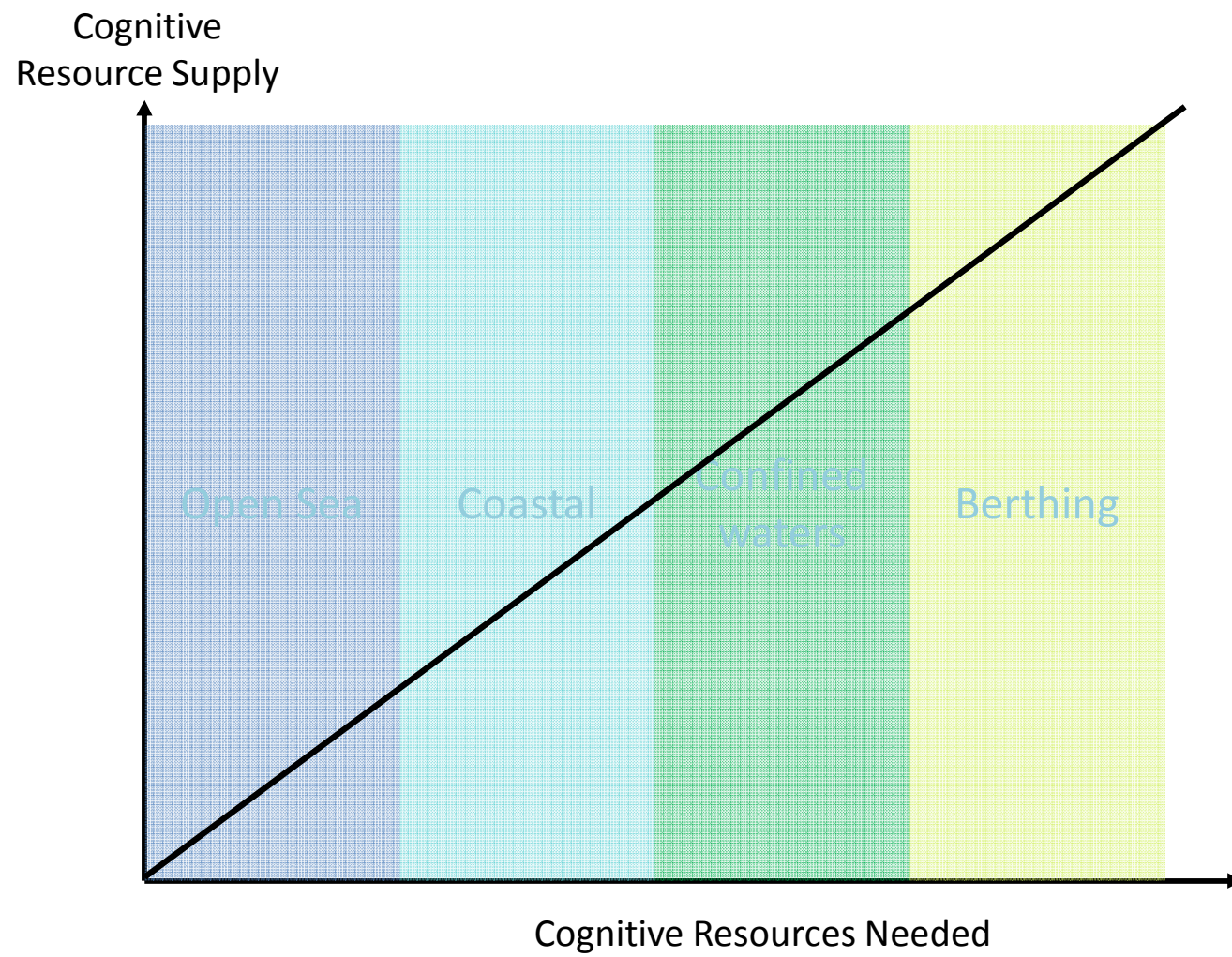

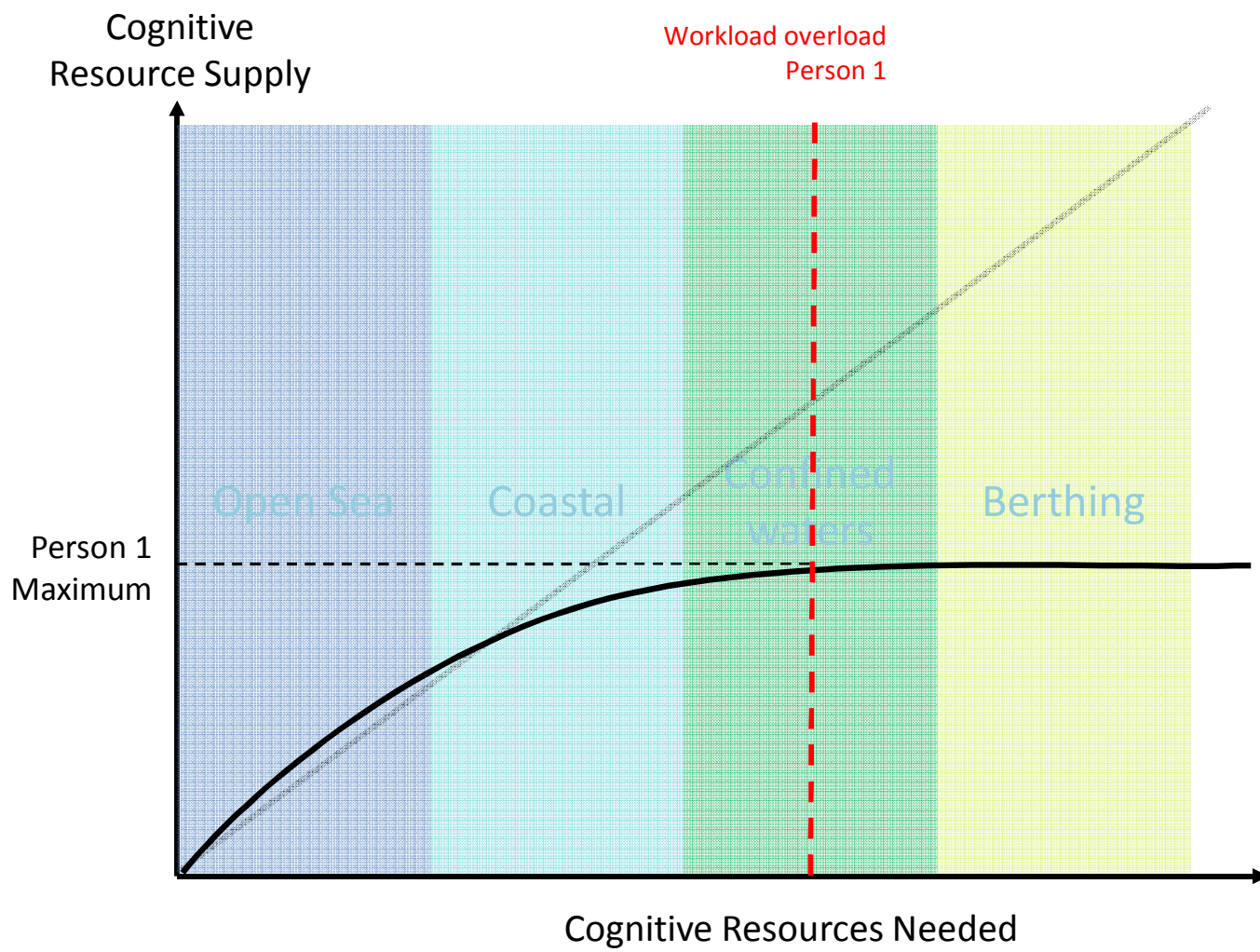

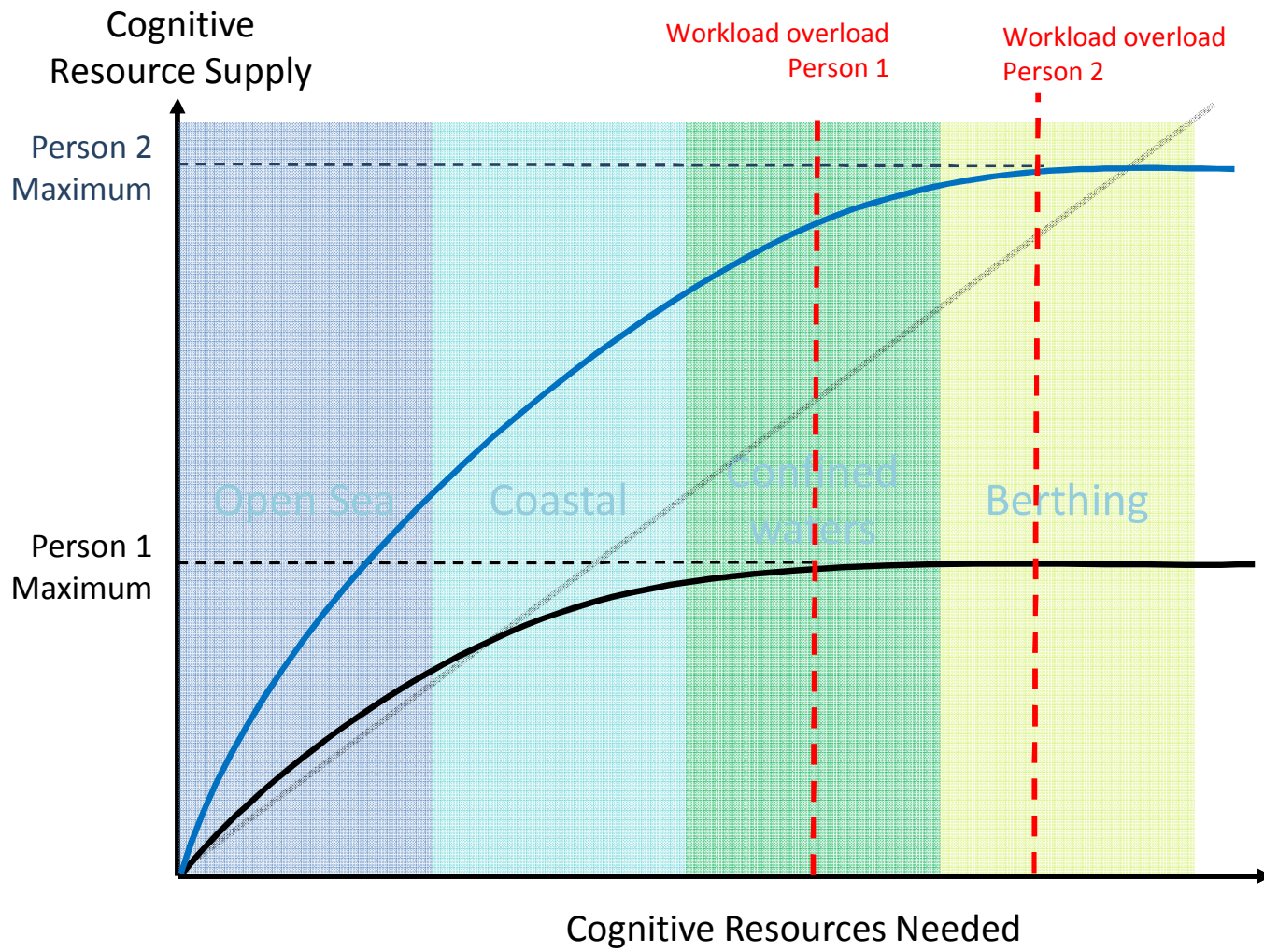

Contextual Control Model (COCOM), Erik Hollnagel, 2005

Control mode	Number of goals	Subjectively available time	Evaluation of outcome	Selection of action
Strategic	Several	Abundant	Elaborate	Based on modes/predictions
Tactical	Several (limited)	Adequate	Detailed	Based on plans/experience
Opportunistic	One or two (competing)	Just adequate	Concrete	Based on habits/association
Scrambled	One	Inadequate	Rudimentary	Random

Hollnagel, E & Woods, D.D. (2005). *Joint Cognitive Systems: Foundations of Cognitive Systems Engineering*. CRC Press

Contextual Control Model (COCOM), Erik Hollnagel, 2005

Control mode	Number of goals	Subjectively available time	Evaluation of outcome	Selection of action
Strategic	Several	Abundant	Elaborate	Based on modes/predictions
Tactical	Several (limited)	Adequate	Detailed	Based on plans/experience
Opportunistic	One or two (competing)	Just adequate	Concrete	Based on habits/association
Scrambled	One	Inadequate	Rudimentary	Random

Hollnagel, E & Woods, D.D. (2005). *Joint Cognitive Systems: Foundations of Cognitive Systems Engineering*. CRC Press



MV Rena, N.Z. 2011

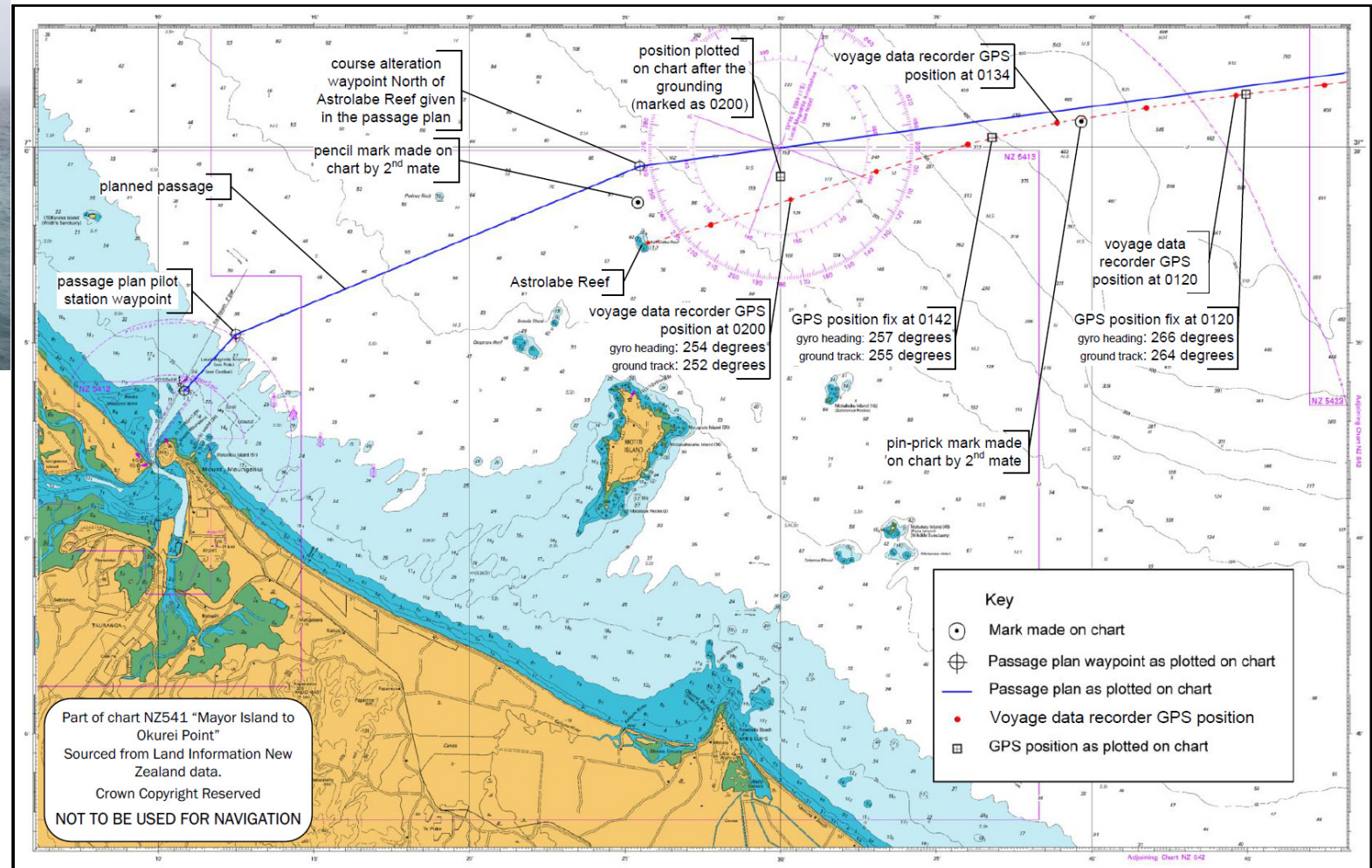

Figure 3
Part of chart NZ541 showing passage plan (course line), plotted positions and voyage data recorder GPS positions on approach to Tauranga



MV Rena, N.Z. 2011

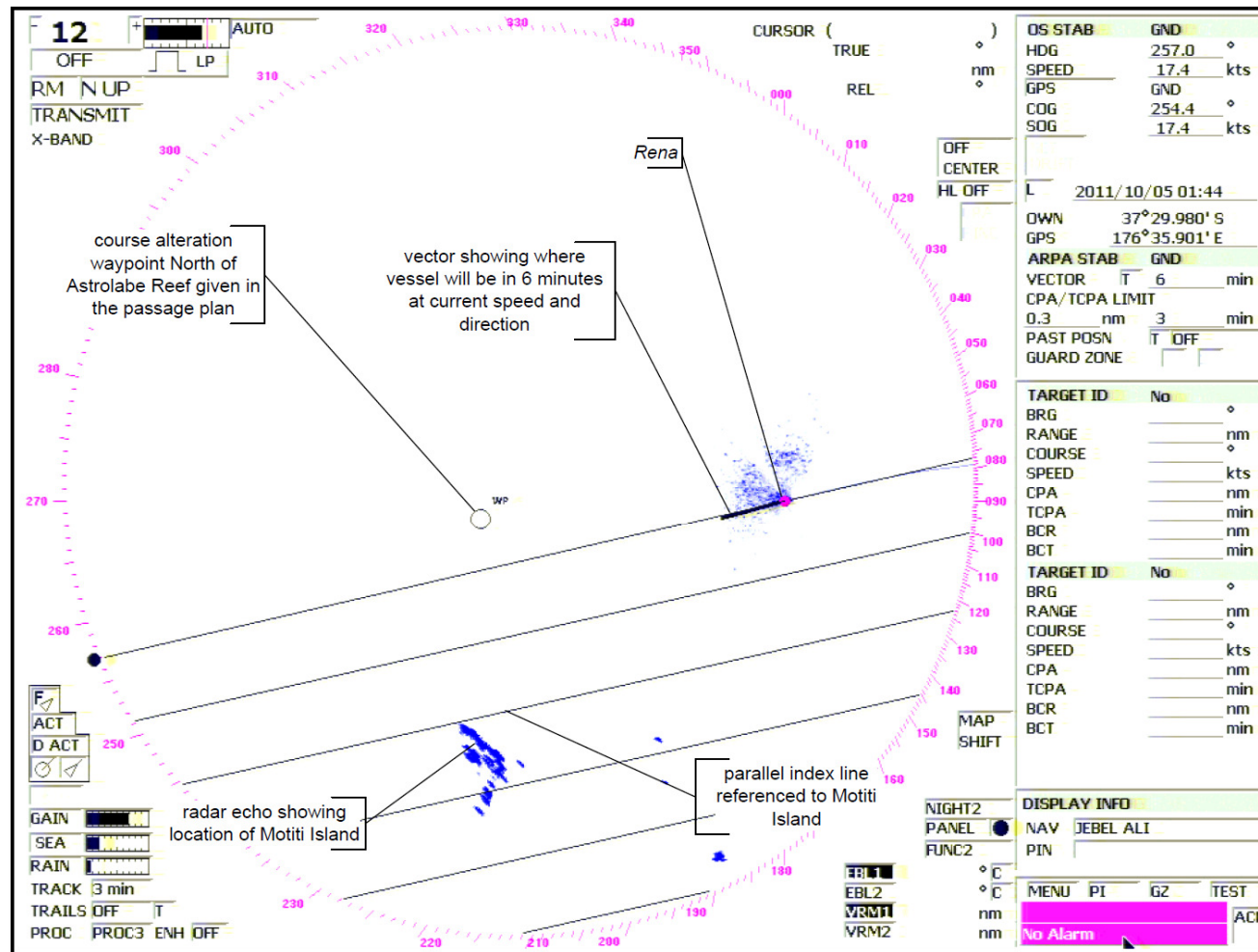
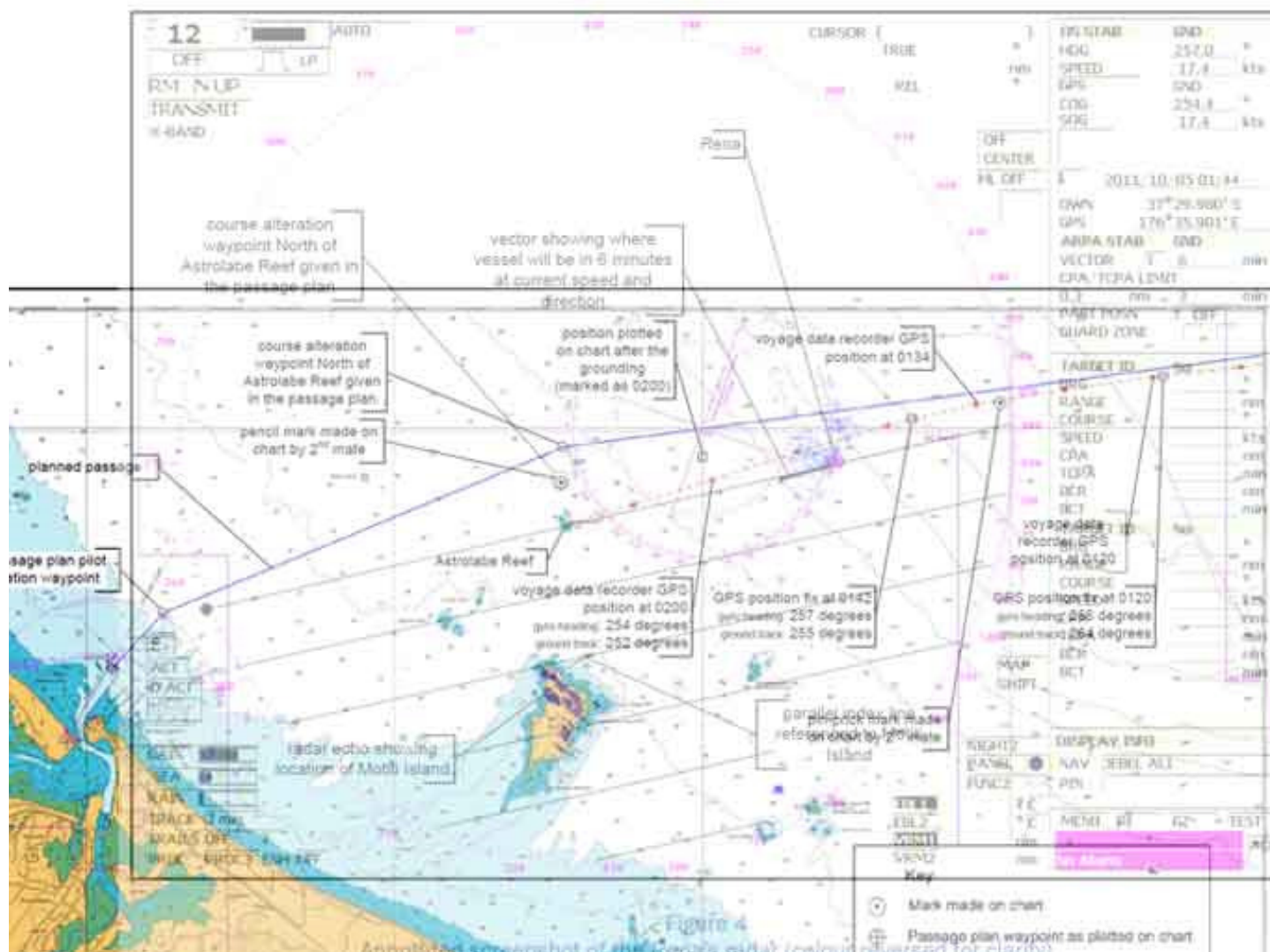

Figure 4
Annotated screenshot of the *Rena*'s radar (colour reversed for clarity)



thomas.porathe@ntnu.no

Contextual Control Model (COCOM)

(Erik Hollnagel, 2005)

Control mode	Number of goals	Subjectively available time	Evaluation of outcome	Selection of action
Strategic	Several	Abundant	Elaborate	Based on modes/predictions
Tactical	Several (limited)	Adequate	Detailed	Based on plans/experience
Opportunistic	One or two (competing)	Just adequate	Concrete	Based on habits/association
Scrambled	One	Inadequate	Rudimentary	Random

Hollnagel, E & Woods, D.D. (2005). *Joint Cognitive Systems: Foundations of Cognitive Systems Engineering*. CRC Press

Contextual Control Model (COCOM)

(Erik Hollnagel, 2005)

Control mode	Number of goals	Subjectively available time	Evaluation of outcome	Selection of action
Strategic	Several	Abundant	Elaborate	Based on modes/predictions
Tactical	Several (limited)	Adequate	Detailed	Based on plans/experience
Opportunistic	One or two (competing)	Just adequate	Concrete	Based on habits/association
Scrambled	One	Inadequate	Rudimentary	Random

Hollnagel, E & Woods, D.D. (2005). *Joint Cognitive Systems: Foundations of Cognitive Systems Engineering*. CRC Press



HSC Sleipner, 1999



Figur 6.1 Bilde av Store Bloksen sett mot øst

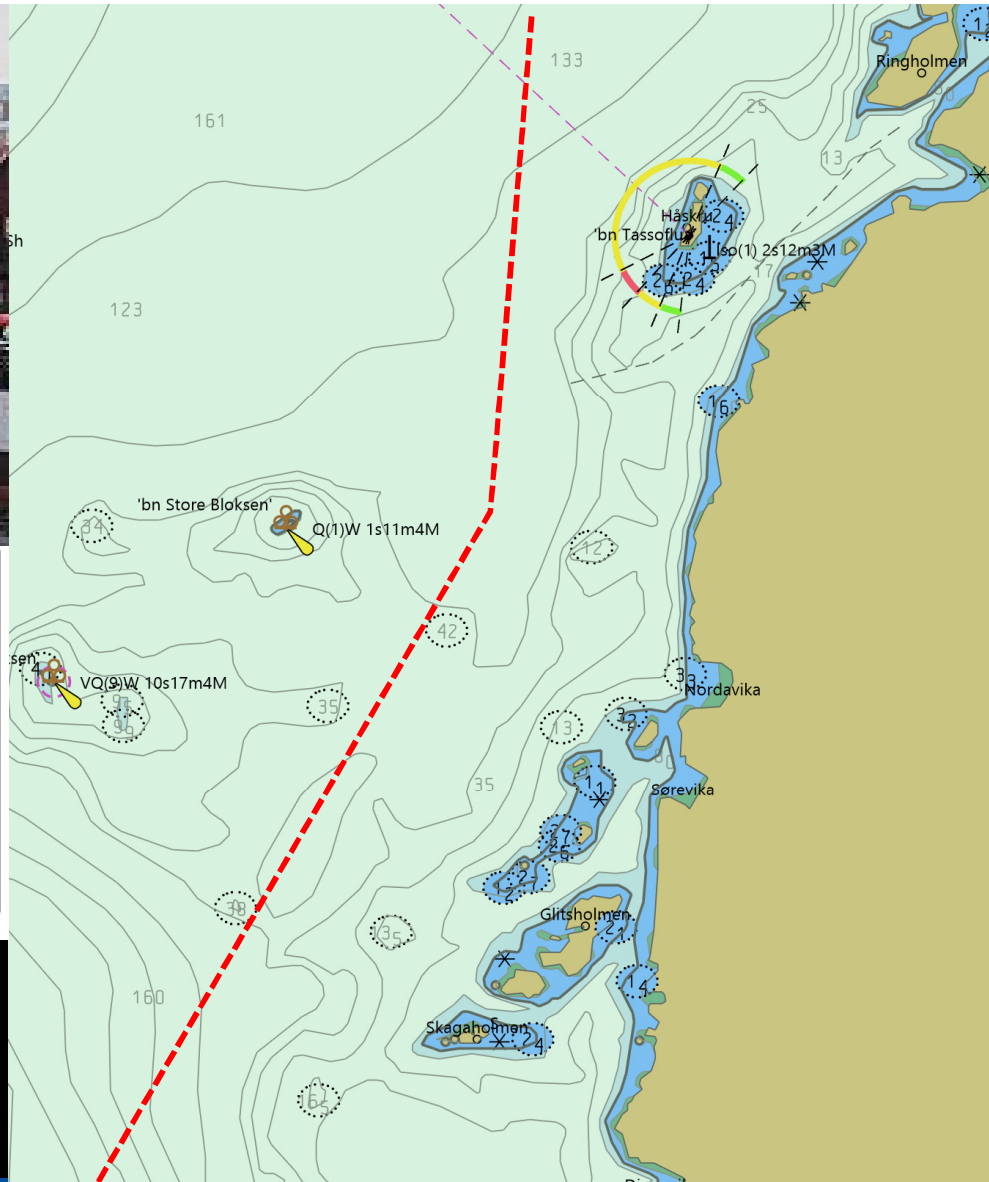

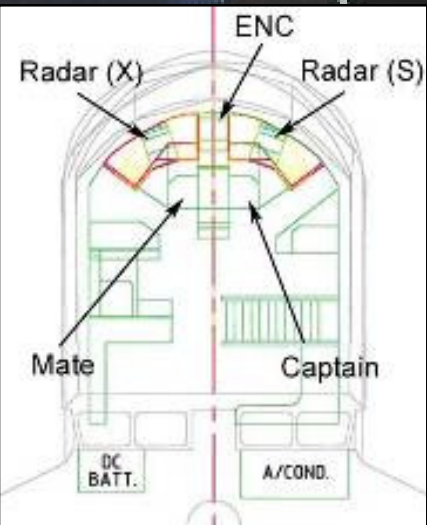

The identical bridge on Sleipner's sister ship Draupner

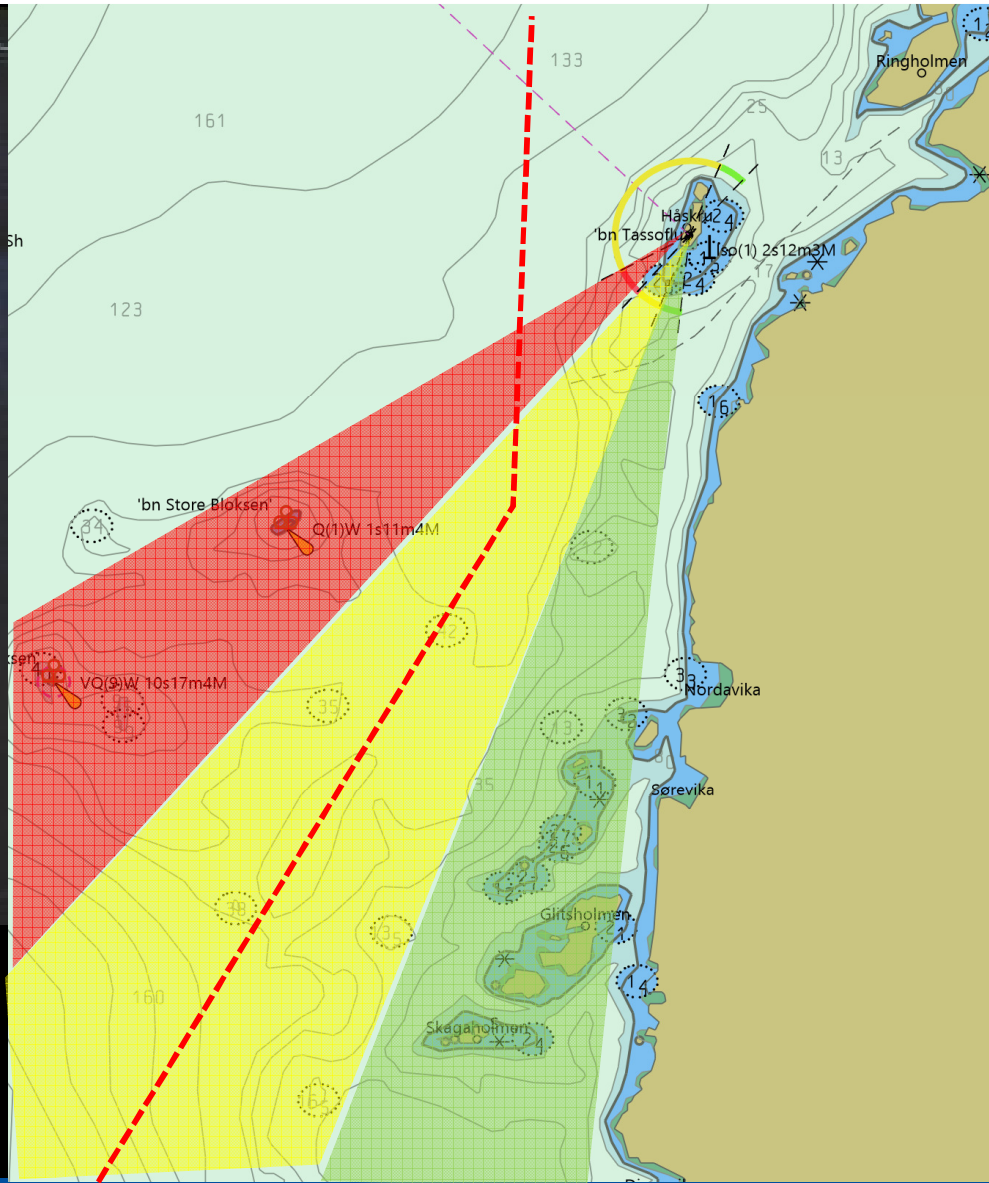

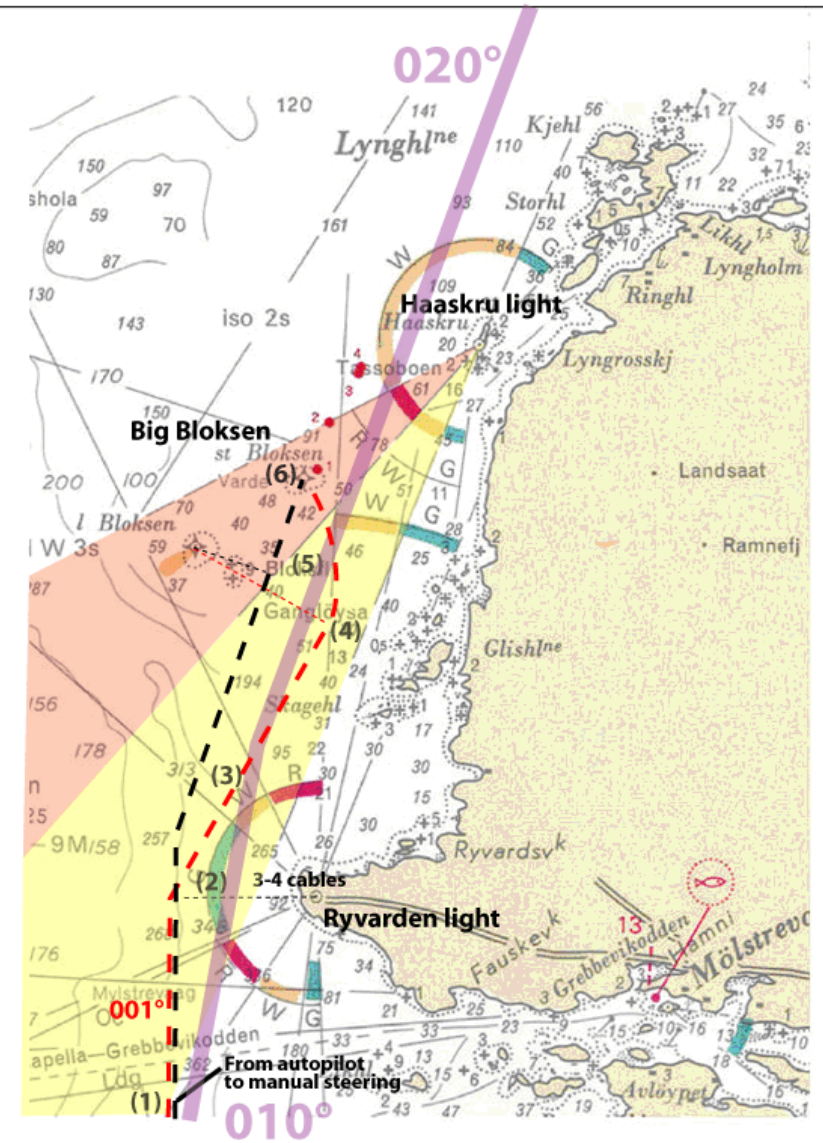

Positions of the wreckage:

1. Starboard Main Engine
2. Main Section of the Ship
3. Panels
4. The Bow Section

- - - The course according to the captain
- - - The course according to the court
— The course in the passage plan

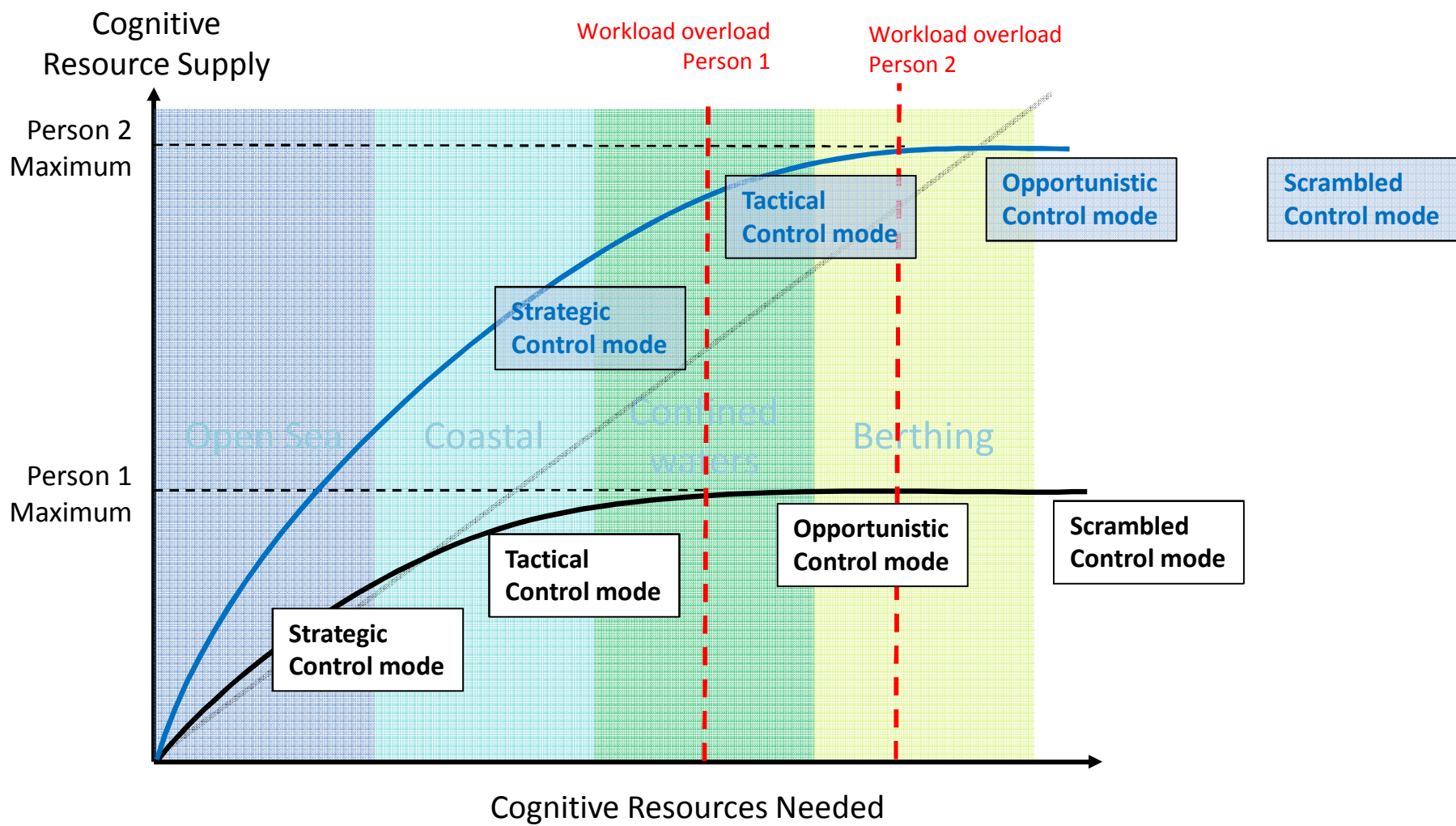

Display of e-Navigation information

Where do we display all this new information?

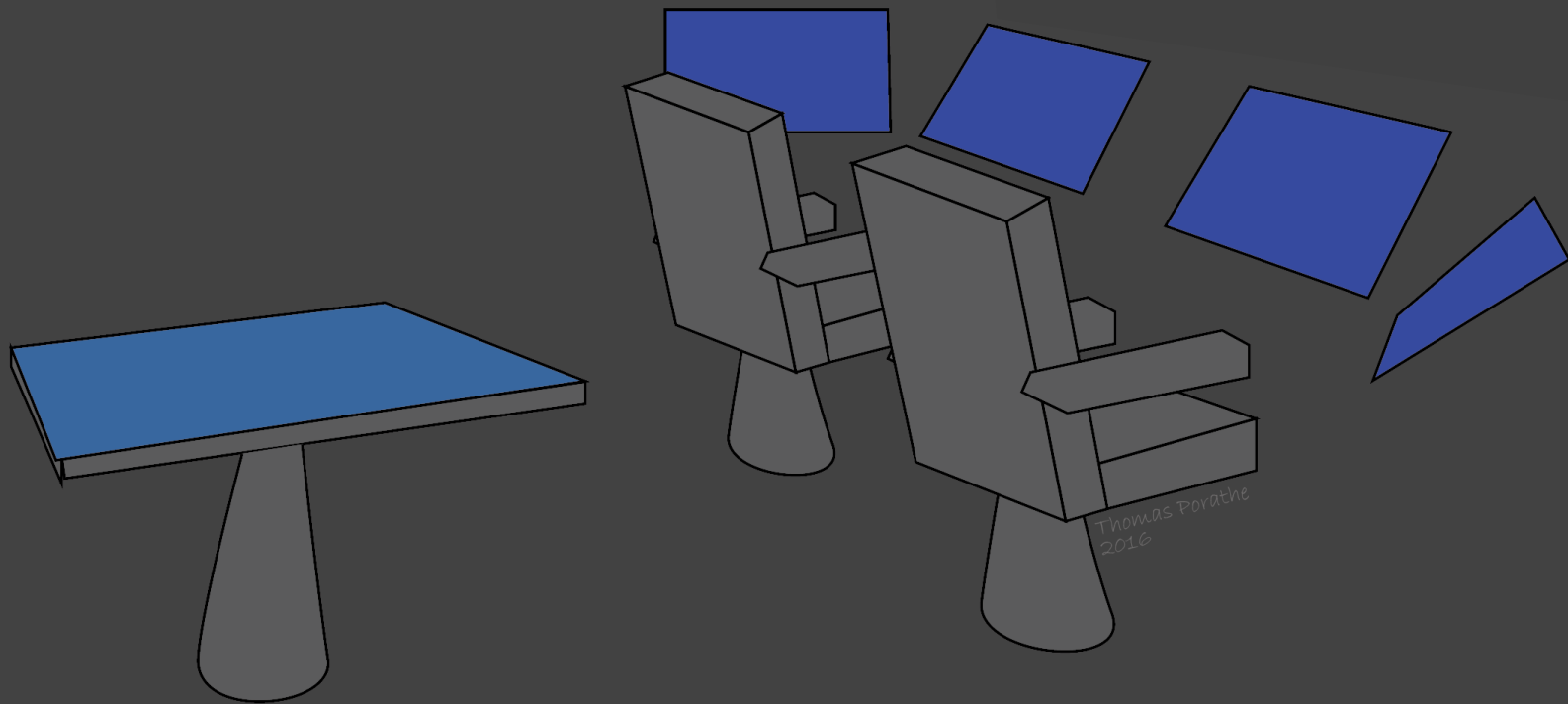

Strategic navigation

”Back bridge”

(Electronic table, iPad, LapTop, ...)

Most e-Nav information

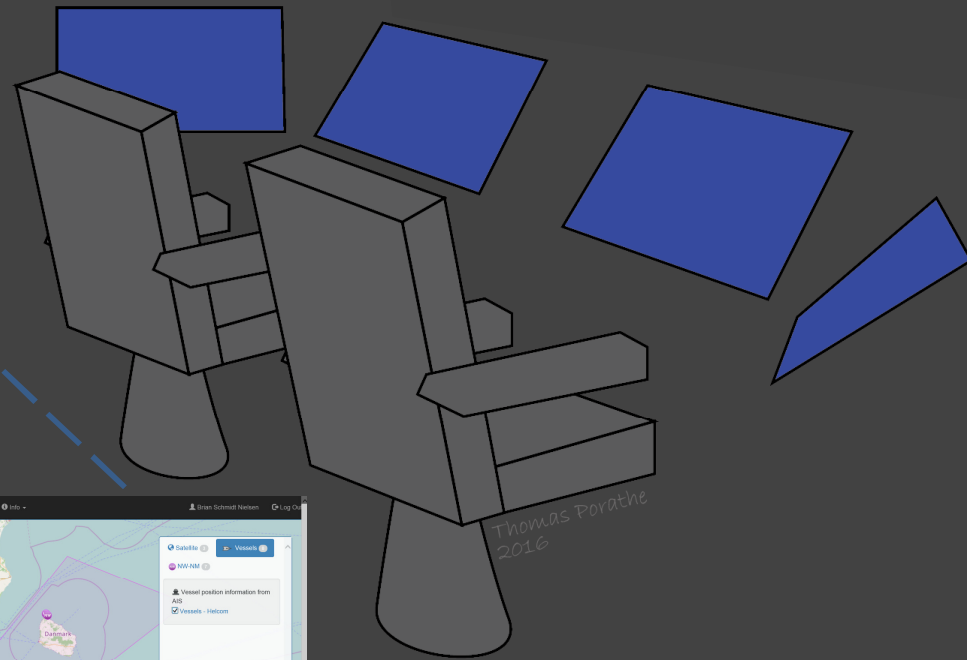
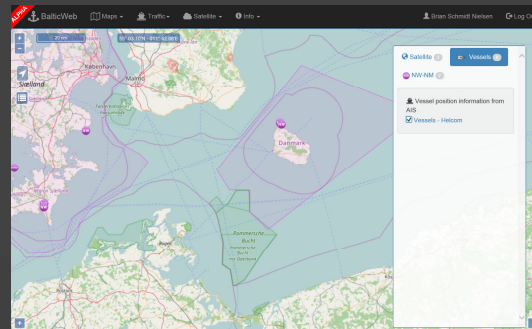
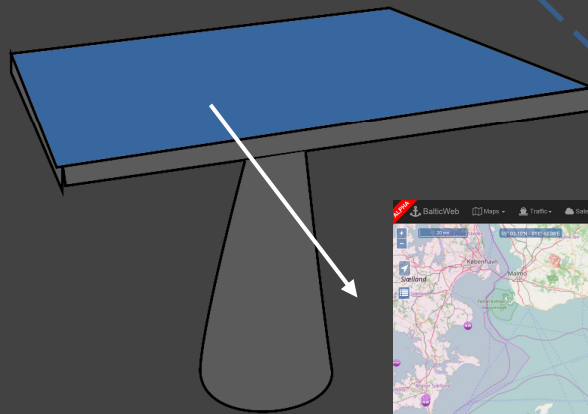

Electronic chart tables OSMOS project

Focus group with captains
Chalmers 2013



thomas.porathe@ntnu.no

Strategic navigation

"Back bridge"

(Electronic table, iPad, LapTop, ...)

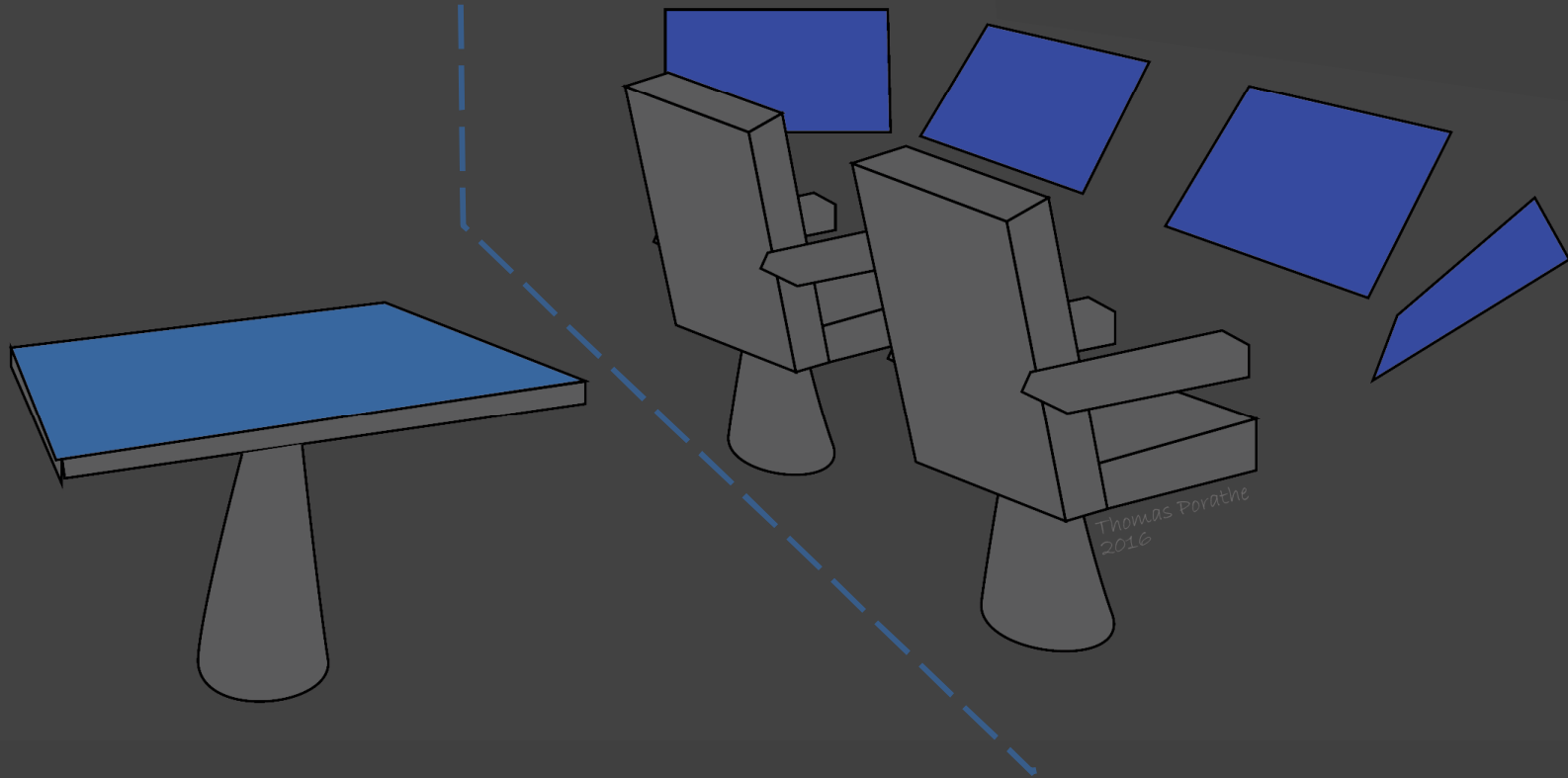

Strategic navigation

”Back bridge”

(Electronic table, iPad, LapTop, ...)

Tactical navigation

”Front bridge”

(INS)

Certain e-Nav information

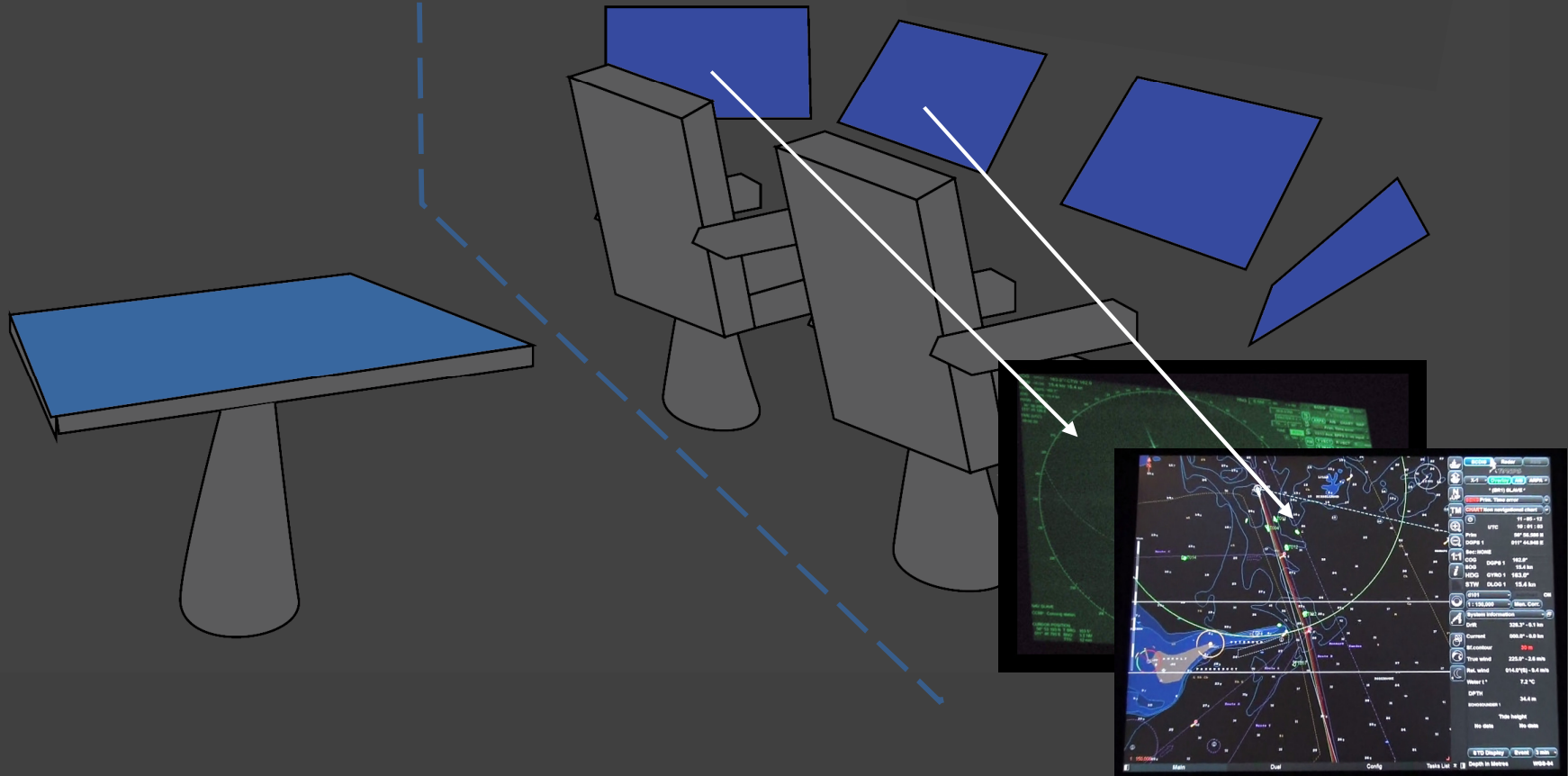

ECDIS

Radar



thomas.porathe@ntnu.no



ECDS Radar

X-1 **Overlay** **AR** **ARPA**

(BR1) SLAVE

GEN Prim. Time error

CHART Non navigational chart

11-05-12

UTC 10:01:03

Prim 56° 56.506 N

DGPS 1 011° 44.948 E

Sec: NONE

COG DGPS 1 162.8°

SOG 15.4 km

HDG GYRO 1 163.0°

STW DLOG 1 15.4 km

d101 ON

1:150,000 Man. Corr.

System Information

Drift 328.3° - 0.1 km

Current 000.0° - 0.0 km

Bf.contour 30 m

True wind 223.0° - 2.6 m/s

Rel. wind 014.0°(8) - 0.4 m/s

Water t° 7.2 °C

DPTH 34.4 m

ECHOSOUNDER 1

Tide height No data No data

STD Display Event 3 min

Depth In Metres WGS-84

1:150,000

Main

Dual

Config

Tasks List

Depth In Metres

WGS-84

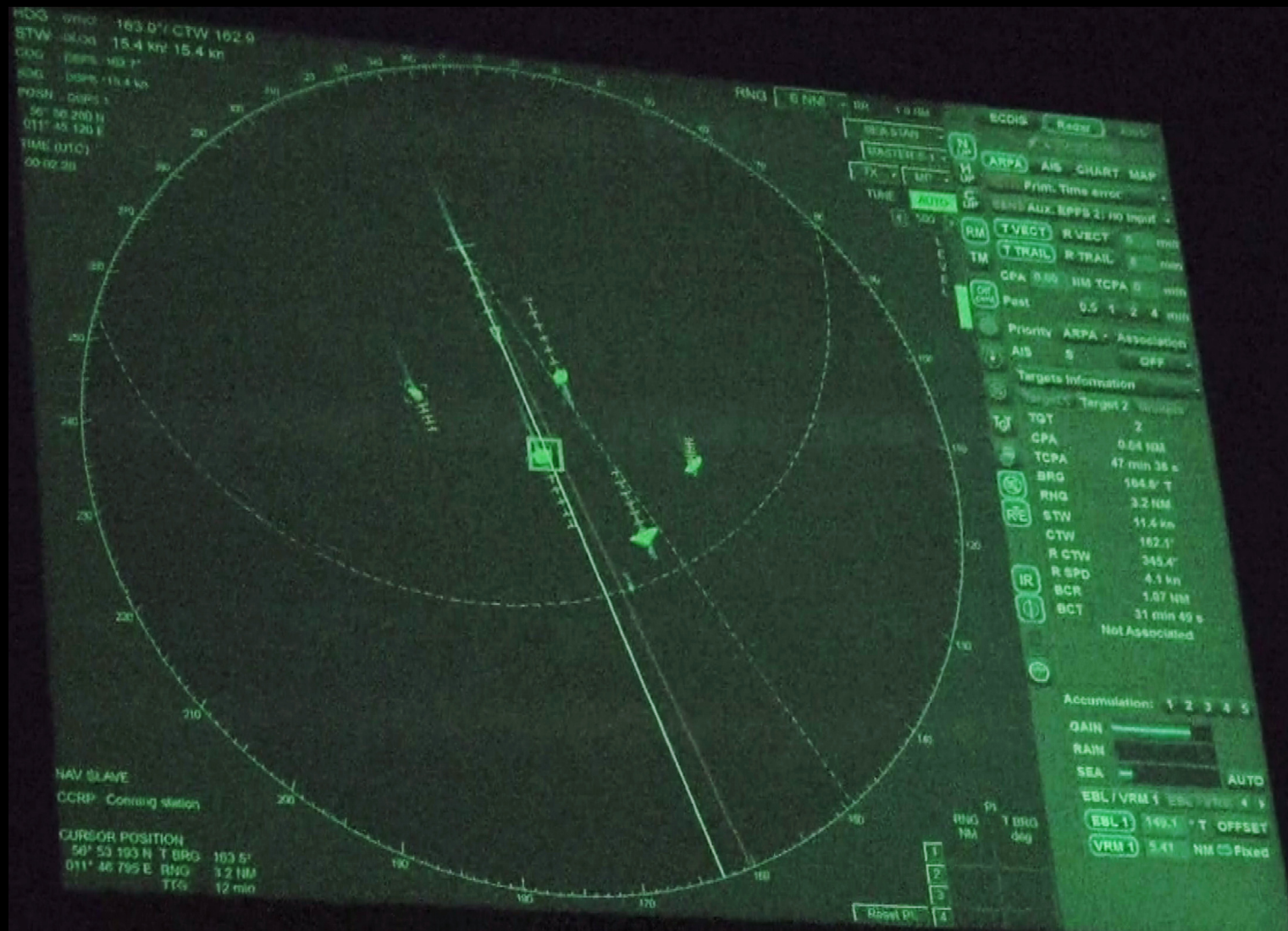

thomas.porathe@ntnu.no

Strategic navigation

"Back bridge"

(Electronic table, iPad, Laptop, ...)

Tactical navigation

"Front bridge"

(INS)

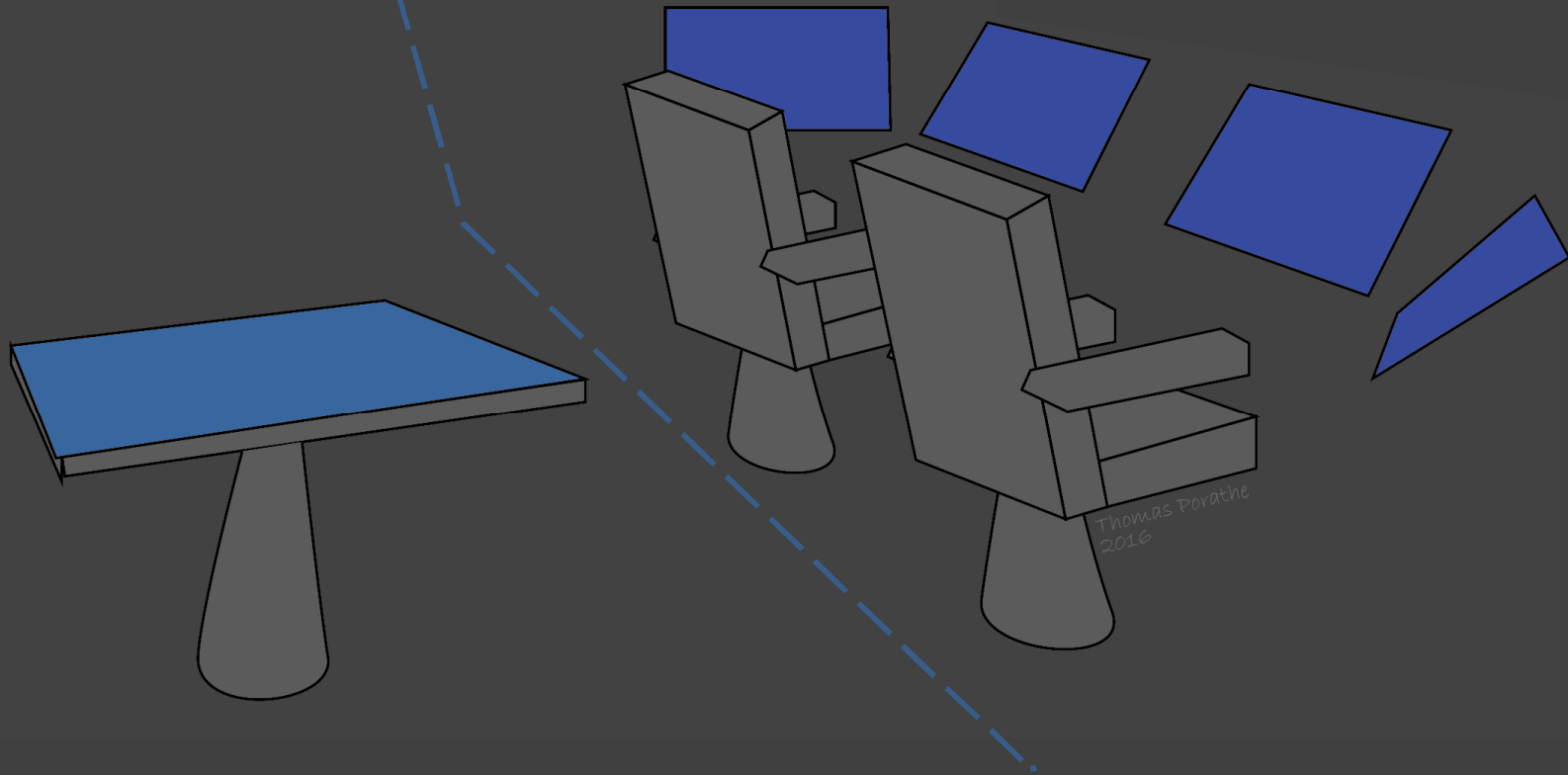

Strategic navigation
"Back bridge"
(Electronic table, iPad, Laptop, ...)

Tactical navigation
"Front bridge"
(INS)

Opportunistic navigation
One fused simplified display
(Head-up ECDIS with radar overlay)

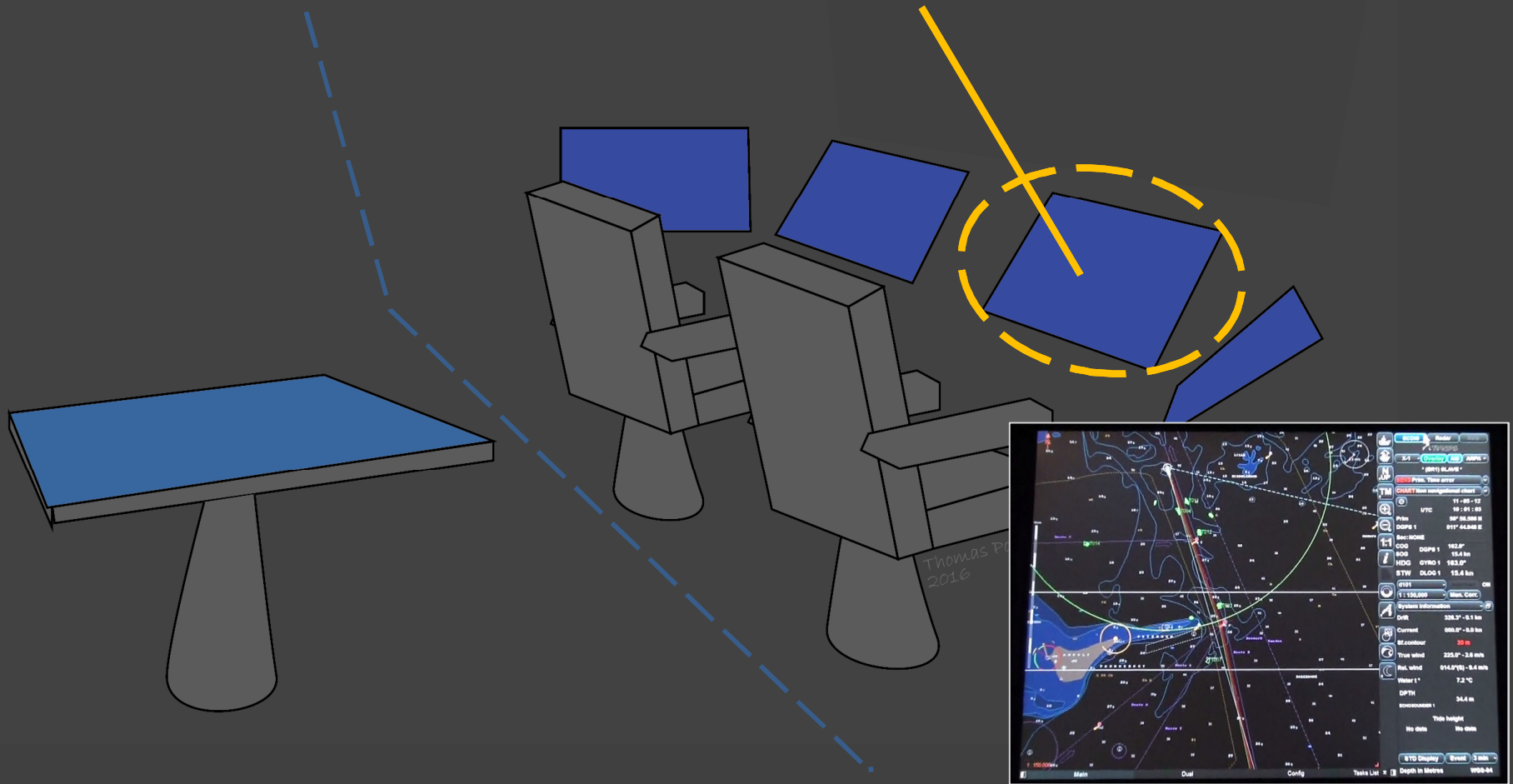

Strategic navigation
"Back bridge"
(Electronic table, iPad, Laptop, ...)

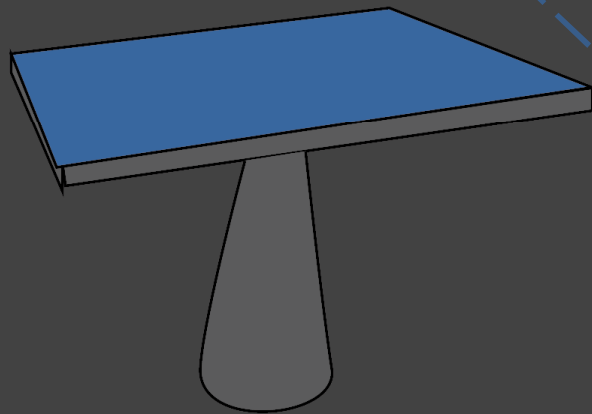

Tactical navigation
"Front bridge"
(INS)

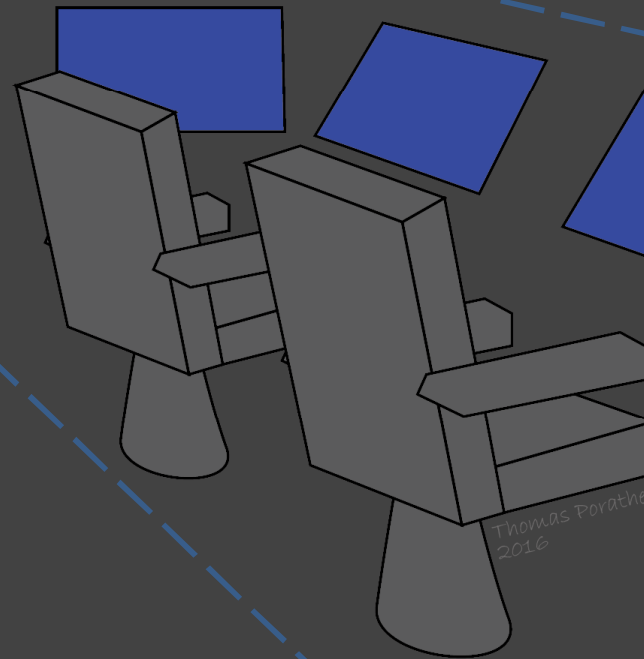

Opportunistic navigation
One fused simplified display
(Head-up ECDIS with radar overlay)



Scrambled navigation
(Conning, HUD, HMD, ...)

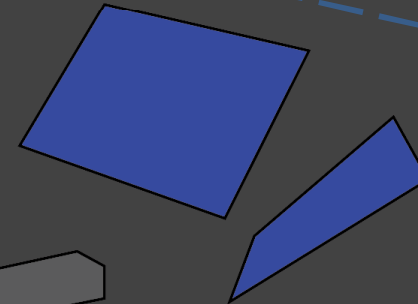

Thomas Porathe
2016

Strategic navigation
"Back bridge"
(Electronic table, iPad, LapTop, ...)

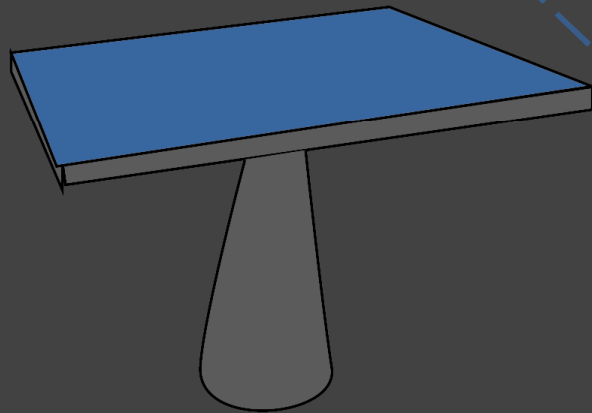

Tactical navigation
"Front bridge"
(INS)

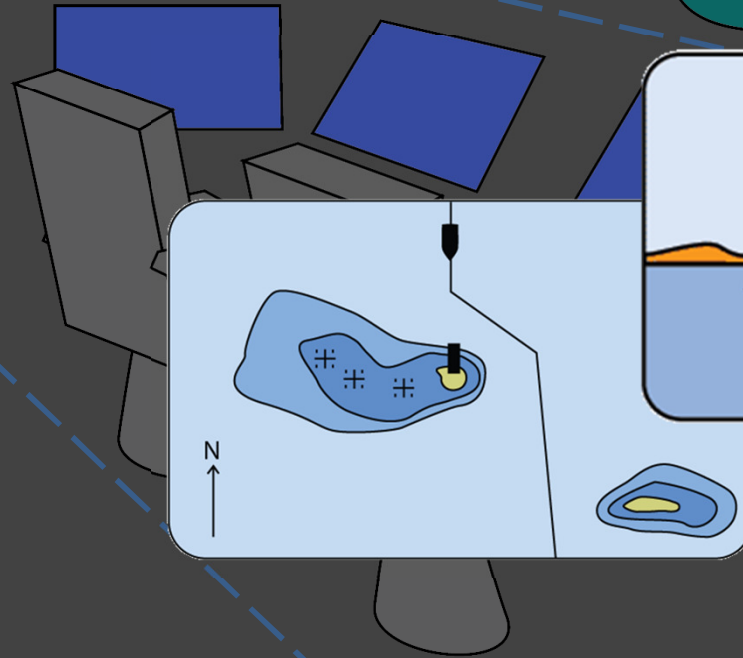

Opportunistic navigation
One fused simplified display
(Head-up ECDIS with radar overlay)

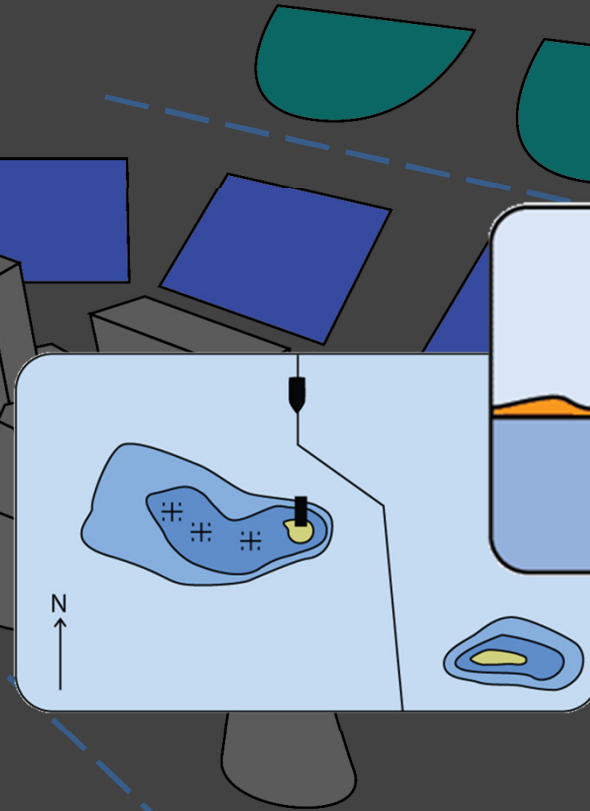

Scrambled navigation
(Conning, HUD, HMD, ...)

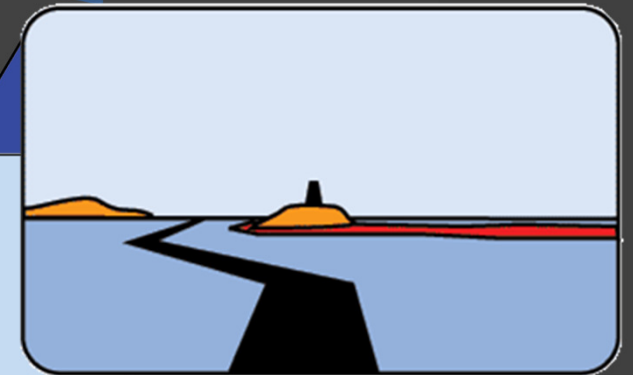



<https://www.flickr.com/photos/rolls-royceplc/15354513854/in/set-72157647334399764/>



Strategic navigation
"Back bridge"
(Electronic table, iPad, Laptop, ...)

Tactical navigation
"Front bridge"
(INS)

Opportunistic navigation
One fused simplified display
(Head-up ECDIS with radar overlay)

Scrambled navigation
(Conning, HUD, HMD, ...)

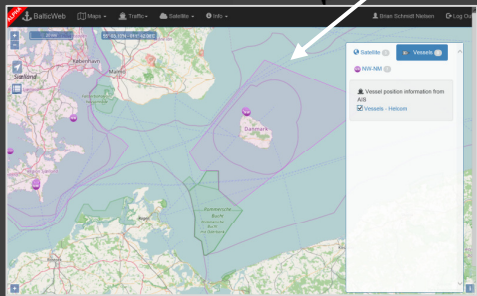

Most e-Nav information

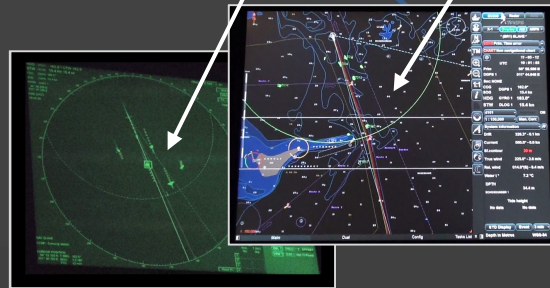

Some e-Nav information



Some carefully selected e-Nav information

